

WRM60/WRM90

SMART MPPT CHARGE CONTROLLERS



Manuale utente

IT

User manual

EN

WESTERN CO. S.r.l.

Via Pasubio, 1 - 63074 San Benedetto del Tronto (AP)

Tel. +39 0735 751248 - Fax +39 0735 751254

info@western.it - www.western.it

 **WESTERN CO.**[®]
ELECTRONIC EQUIPMENTS - SOLAR SYSTEMS

Disposizioni generali di sicurezza:

- E' obbligatorio leggere attentamente questo manuale prima di installare o utilizzare il prodotto.
- Se il prodotto non è installato e utilizzato come riportato in questo manuale il prodotto non può essere considerato sicuro, quindi potrebbe danneggiare persone animali o cose.

Installazione e manutenzione:

- Il prodotto deve essere installato solo da personale qualificato.
- Assicurarsi che le batterie in uso siano compatibili con il prodotto verificando sulla loro scheda tecnica il tipo di batteria, la tensione nominale e la tensione di carica.
- Assicurarsi che il locale batteria sia adeguatamente ventilato come indicato nel manuale di installazione della batteria.
- Quando si connette la batteria si possono generare scintille che possono danneggiare la retina dell'operatore.
- Quando il modulo fotovoltaico è esposto al sole genera tensione. Se il pannello ha tensione $V_{oc} > 50V$ è obbligatorio usare guanti isolanti per proteggere l'installatore dalla scossa elettrica.
- Per la manutenzione della batteria fare riferimento al manuale di manutenzione della batteria.
- Il prodotto non può essere riparato dall'utente o dal personale che esegue l'installazione; non deve essere quindi aperto o lasciato funzionare con il pannello aperto.
- Non installare il prodotto in luogo dove potrebbero verificarsi esplosioni di gas o polvere.
- Proteggere dal cortocircuito i cavi con adeguati fusibili, in particolare è obbligatorio posizionare un fusibile di adeguata corrente sul cavo di batteria quanto più possibile vicino al morsetto positivo di batteria.

General safety Instructions:

- It is mandatory to read this manual carefully before installing or using the product.
- If the product is not installed and used as described in this manual the product cannot be considered safe, so it could damage people or animals.

Installation and maintenance:

- The product must be installed only by qualified personnel.
- Make sure that the batteries in use are compatible with the product by checking the battery type, the nominal voltage and the charging voltage on their data sheet.
- Make sure that the battery room is properly ventilated as indicated in the battery installation manual.
- When connecting the battery, sparks can occur which can damage the operator's retina.
- When the photovoltaic module is exposed to the sun it generates voltage. If the panel has voltage $V_{oc} > 50V$ it is mandatory to use isolating gloves to protect the installer from electric shock.
- For battery maintenance refer to the battery maintenance manual.
- The product cannot be repaired by the user or by the personnel performing the installation; it must not therefore be opened or left working with the panel open.
- Do not install the product in a place where gas or dust explosions may occur.
- Protect cables with suitable fuses from the short-circuit, in particular it is mandatory to place a fuse of adequate current on the battery cable as close as possible to the positive battery terminal.

SERIE SEHM - WRM60/WRM90 - IoT SMART CHARGE CONTROLLER 12/24/48V MPPT 60/90A

Modelli	Descrizione
WRM60 M - SB	IoT Smart Master C.C. MPPT 60A Shunt Battery Monitor
WRM90 M - SB	IoT Smart Master C.C. MPPT 90A Shunt Battery Monitor
WRM60 M - CB	IoT Smart Master C.C. MPPT 60A CAN Battery Monitor
WRM90 M - CB	IoT Smart Master C.C. MPPT 90A CAN Battery Monitor
WRM60 S	IoT Smart Slave C.C. MPPT 60A 12/24/48V
WRM90 S	IoT Smart Slave C.C. MPPT 90A 12/24/48V



La serie WRM60/90 include dei regolatori MPPT da 60/90A per sistemi 12/24/48V, con n.2/3 ingressi PV indipendenti e Battery Monitor per batterie al Piombo o Litio. Grazie alla tecnologia IoT e alla connessione ad internet di serie, i dispositivi permettono sia il monitoraggio che la configurazione da remoto. Sono particolarmente indicati per impianti fotovoltaici professionali di elevate dimensioni.

Il **WRM60/90 M - CB** (Master - CAN Battery) è progettato per batterie al Litio con BMS integrato e interfaccia CAN-BUS. Il **WRM60/90 M - SB** (Master - Shunt Battery) dispone, invece, di un proprio Battery Monitor **WBM** che riesce a controllare i flussi energetici della batteria comunicando tramite il **WBUS**. Il **WBUS** è un bus di controllo proprietario per comunicare con i vari dispositivi compatibili, in grado di accedere a tutti i parametri sia per la visualizzazione che per la gestione delle funzioni di controllo.

La serie WRM60/90 fa parte del **WESTERN WRD SYSTEM**: un sistema stand-alone flessibile e avanzato, con monitoraggio dei dati e controllo remoto da internet, attraverso una piattaforma cloud. Il sistema è modulare in quanto è possibile aggiungere all'impianto i **WRM60/90 S** (Slave) per ottenere potenze di carica fino a 14kW.

La semplice interfaccia utente, con display 128x64 e 4 tasti, permette una immediata visualizzazione di tutti i parametri: potenze, tensioni, correnti di carica e di stringa PV, contatori di energia, logger data e eventi.

Le due varianti del **WRM60/90 M** (SB e CB) permettono l'attivazione intelligente di carichi connessi al sistema per una gestione efficiente della batteria.

Nella μ SD removibile sono memorizzati i dati del logger. Attraverso la connessione internet è possibile il collegamento al cloud **WRM MONITOR** per il monitoraggio e il controllo remoto del proprio impianto.

- **Tensione di batteria: 12/24/48V**
- **Autodetect 12/24/48V**
- **2/3 canali MPPT di ricarica indipendenti**
- **Massima potenza PV**
 - 900/1350W..3600W @ 12V
 - 1800/2700W..7200W @ 24V
 - 3600/5400W..14400W @ 48V
- **Max tensione Voc sui moduli PV 180V**
- **Compatibile con batterie a ioni di litio, LiFePO4, Pb Gel/AGM**
- **Gestione profili smart battery**
- **Gestione dello Stato di Carica**
- **Connessione internet**
- **Tecnologia CLOUD IoT**
- **Monitoraggio e gestione remota in cloud**
- **Interfaccia WBUS**
- **Data logger su μ SD estraibile**
- **LCD retroilluminato e navigazione menu con 4 tasti**
- **Protezione anti inversione**
- **Protezione sovra-temperatura**
- **Protezione inversione polarità batteria**
- **Protezione sovraccarico su uscita Load**
- **Curva di derating**
- **Integra il WESTERN WRD SYSTEM**
- **Contenitore metallico IP20**
- **Cavi batteria 24mmq**
- **Connessioni moduli MC4**
- **Morsetti estraibili su uscite ALARM e LOAD**

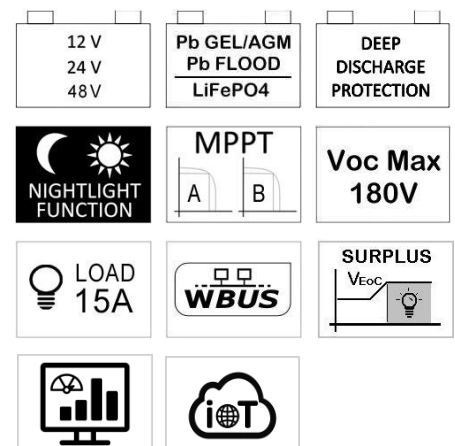

Descrizione generale

Il **WRM60/90 M - SB** è utilizzato in un impianto stand-alone con tipologia di batteria Pb Seal/Gel o Flood oppure con batterie al Litio con VEOC comprese nel range¹ e che, pur avendo un BMS integrato, non dispongono di comunicazione CAN. Il battery monitor **WBM** provvede alla contabilizzazione dell'energia in ingresso e in uscita della batteria, nonché alla sua gestione (vedi manuale WBM per maggiori dettagli).

Il **WRM60/90 M - CB** è utilizzato in un impianto stand-alone con tipologia di batteria Smart (dotate di comunicazione CAN) compresa nei profili compatibili¹.

WESTERN WRD SYSTEM

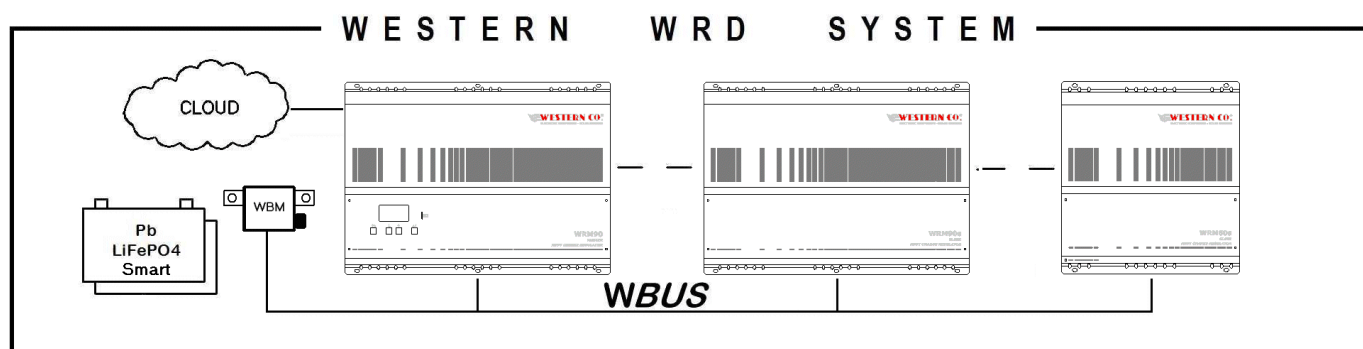

Fig.1 - WESTERN WRD SYSTEM

Il **WESTERN WRD SYSTEM** un sistema stand-alone modulare, composto da un **WRM60/90 M** (Master) e uno o più **WRM60/90 S** (Slave) per ottenere potenze di carica fino a 14kW. Il Master è il coordinatore del sistema: modifica dinamicamente alcuni parametri al fine di ottimizzare la gestione dell'energia dell'intero sistema e di garantire il rispetto dei parametri di batteria. Il sistema permette il monitoraggio dei dati e il controllo remoto da internet, attraverso una piattaforma cloud.

La fig.2 mostra le combinazioni Master/Slave ammissibili per la serie **WRM60/90**. Ovviamente la potenza gestita dipende dalla tensione del sistema 12/24/48V (come mostrato in Tab.1)

POSSIBILI COMBINAZIONI	Corrente di Carica (A)	Massima potenza ingresso PV del sistema (kW)		
		Tensione di sistema 12V	Tensione di sistema 24V	Tensione di sistema 48V
1	60	0,9	1,8	3,6
2	90	1,3	2,7	5,4
3	120	1,8	3,6	7,2
4-5	150	2,2	4,5	9
6	180	2,7	5,4	10,8
7	240	3,6	7,2	14,4

Tab.1 - Combinazioni Master / Slave ammissibili

¹ Vedi Tab.2 - Caratteristiche Elettriche alle voci Battery Profiles and End of Charge Voltage.

Combinazioni Master / Slave ammissibili

1
2
3
4
5
6
7

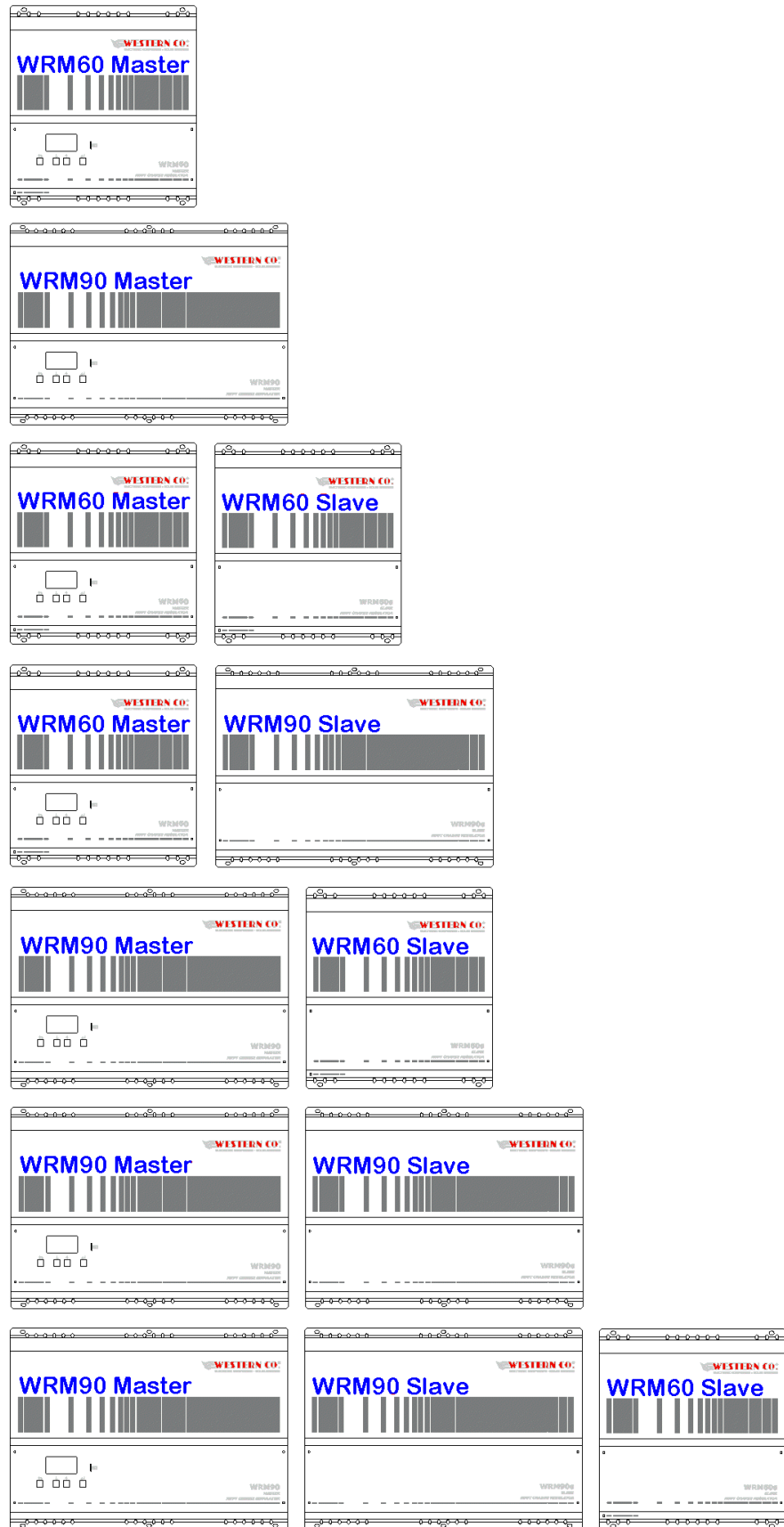

Fig.2 - Combinazioni Master / Slave ammissibili

Collegamenti e installazione

In *Fig.4 e 6* sono rappresentati, rispettivamente, i collegamenti del sistema per le versioni **WRM60 M-SB** e **WRM60 M-CB**. L'esempio illustrato impiega un Master e uno Slave, nel caso si utilizzino più Slave occorre semplicemente replicare le connessioni per ciascuno di essi, mentre con il solo Master basta trascurare i collegamenti dello Slave. Per i modelli **WRM90** vale il medesimo schema, si aggiunge solo la connessione per la terza stringa di moduli: **PV3**.



L'impianto elettrico è a cura dell'installatore, va realizzato rispettando tutti i criteri di sicurezza e inserendo le opportune protezioni.

Procedura d'installazione:

1. Installare il WRM60/90 in un luogo asciutto, utilizzare i due tasselli a gancio per appenderlo a muro e gli altri presenti in dotazione per completare il fissaggio.
2. Effettuare tutti i collegamenti. Per il **WRM60/90-SB**, che prevede anche il collegamento del WBM, vedere *Fig.4 e Fig.5*. Per il **WRM60/90-CB** vedere *Fig.6*.²
 - **Alla prima accensione è fortemente consigliato attivare l'impianto escludendo le stringhe fotovoltaiche e eventuali carichi. Dopo aver impostato il corretto profilo di batteria (punto seguente) e verificato che il sistema non segnali errori, possono essere collegate le stringhe fotovoltaiche verificando quindi i parametri di ricarica. Infine possono essere attivati i carichi.**
3. Eseguire ora le impostazioni di configurazione del sistema che verranno richieste.
 - Nel menu: **7.1 DATE / TIME** si imposta l'orologio di sistema e il fuso orario (Timezone). E' importante impostare correttamente quest'ultimo parametro con il Timezone del sito dove è collocato l'impianto, in maniera che l'aggiornamento dell'orologio da remoto possa avvenire correttamente.
 - Al menu: **7.0 SYSTEM** si eseguono le impostazioni di sistema. **Occorre selezionare il profilo corretto, corrispondente alle caratteristiche di batteria** (una scelta errata potrebbe portare nel tempo a danneggiare la batteria stessa).
 - Impostare la corretta capacità di batteria in Ah, in maniera che il WBM possa calcolare correttamente lo State of Charge (%) di Batteria (non richiesto nella versione WRM-CB).
 - Impostare le soglie per i due contatti comandati in funzione dello State of Charge (%) di Batteria. Si può sfruttare il contatto *Discharge* per comandare un dispositivo capace di disabilitare il carico, determinando così la massima profondità di scarica entro cui ciclerà la batteria. Questo contatto interviene anche in caso di protezioni: overcurrent, overtemperature e undervoltage. Con il contatto *Charge*, normalmente, si comanda un dispositivo capace di disabilitare la carica in quanto esso interviene in caso di protezioni: overcurrent, overtemperature e overvoltage. Impostando le soglie per il contatto *Charge* lo si può comandare anche in funzione dello SoC nel caso alcune applicazioni lo richiedano. Considerato che la carica è eseguita dal WRM60/90 ed è già controllata attraverso il WBUS, normalmente non è necessario sfruttare il contatto *Charge*.
 - Selezionare adeguatamente la programmazione dell'uscita *Load*. Si può sfruttare l'uscita *Load* con programmazione '*SurPlus*' per comandare o alimentare direttamente un carico quando la batteria è carica e c'è ancora energia dai moduli PV per cui abbiamo un esubero di energia che in questa maniera può essere risfruttato.
 - Impostare la soglia di Low Battery per l'uscita *Load*.
4. Collegare le stringhe del fotovoltaico.
5. Verificare l'intero funzionamento scorrendo le videate.

² per i cavi di batteria sono previsti due fermacavo vedi *Fig.3*

6. Collegare i carichi.

- I carichi, ad esempio un inverter, vanno collegati direttamente alla batteria utilizzando come negativo comune il terminale del WBM (se presente).

7. Ulteriori setup da verificare dopo il primo avvio sono:

- Nel menu: **7.2 DATA LOGGER** abilitare il data logger impostando i minuti di campionamento dei parametri: 10min. è il valore predefinito (abilitato). Qui è possibile anche richiedere informazioni riguardanti la μ SD.
- Nel menu: **7.3 NETWORK** si possono impostare i parametri di rete. Di default è impostata la funzionalità DHCP che provvede in automatico a recuperare i valori necessari. Qui è possibile abilitare o meno la connessione al server remoto (default ON).
- Nel menu: **7.4 SYSTEM INFO** si può verificare, alla prima voce, lo stato della connessione.

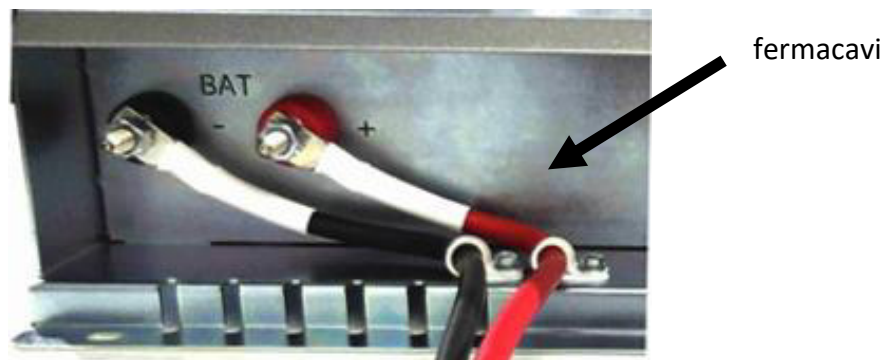

Fig.3 - Cablaggio cavi batteria

Procedura di spegnimento:

Per lo spegnimento dell'impianto potrebbe non essere sufficiente scollegare la batteria, infatti nel caso in cui l'energia del fotovoltaico è sufficiente ad alimentare i carichi l'impianto rimane in funzione.

Per questo motivo è necessario seguire la seguente procedura:

1. Disattivare i carichi.
2. Disattivare tutti gli ingressi fotovoltaici, con sezionatore, oppure sfruttando la funzione del Menu 7.5 -> PAUSE Charge = ON.
3. Disattivare la batteria (con sezionatore o scollegando il polo positivo).

Schema di collegamento WRM60 M - SB + WRM60 S

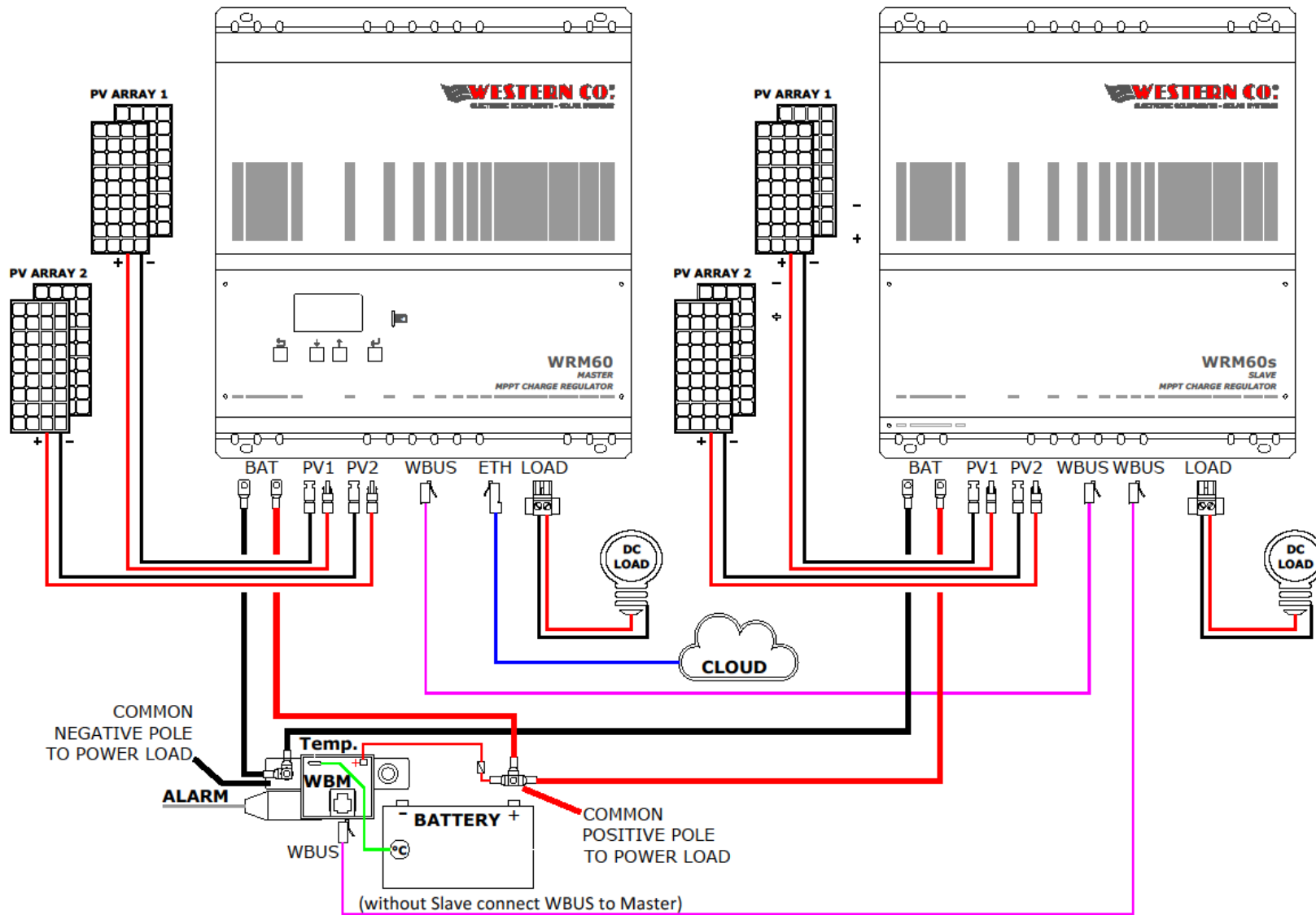

Fig.4 - Schema di collegamento WRM60 M - SB + WRM60 S

Schema di collegamento WBM

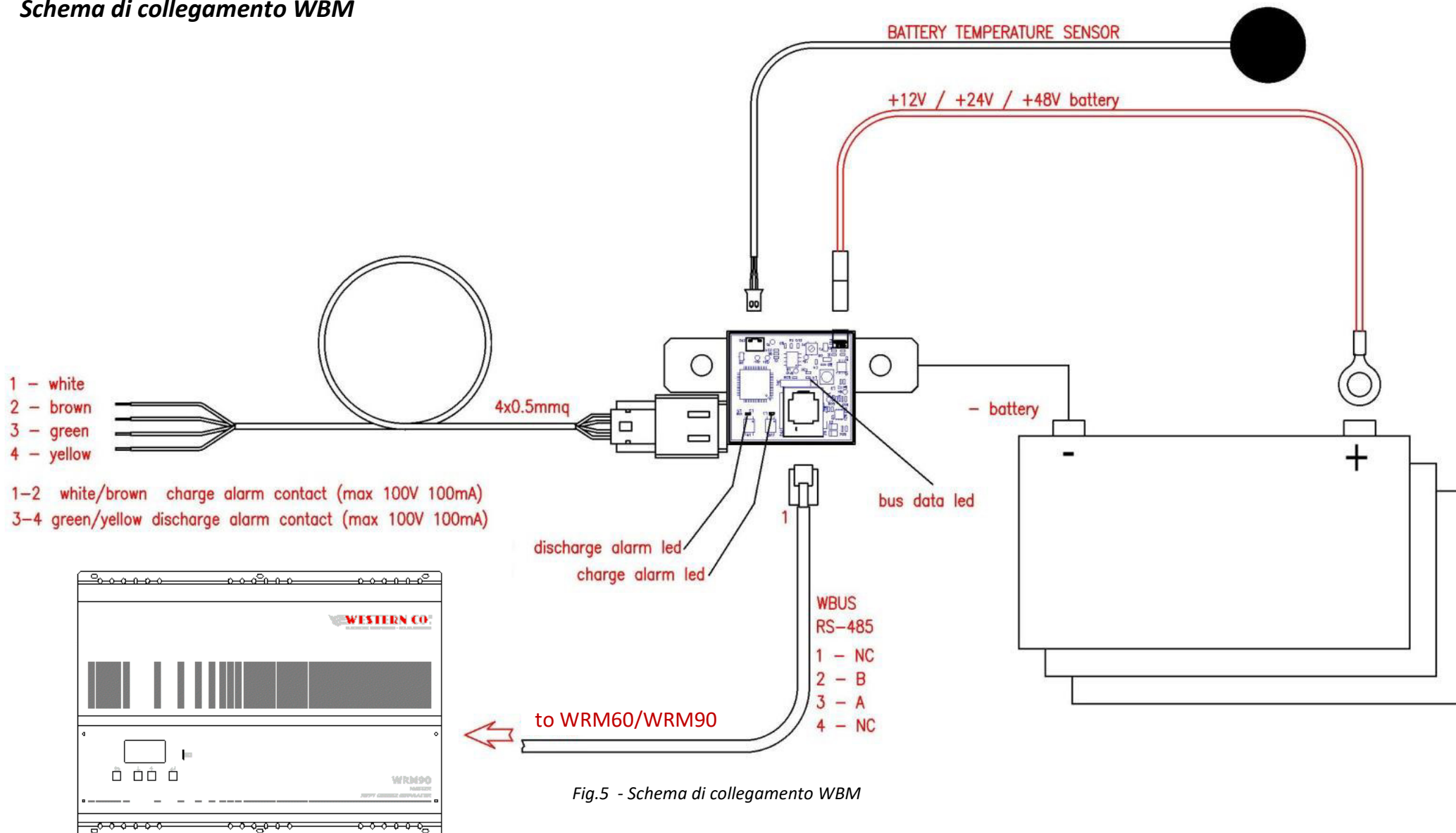

Fig.5 - Schema di collegamento WBM

Schema di collegamento WRM60 M - CB + WRM60 S

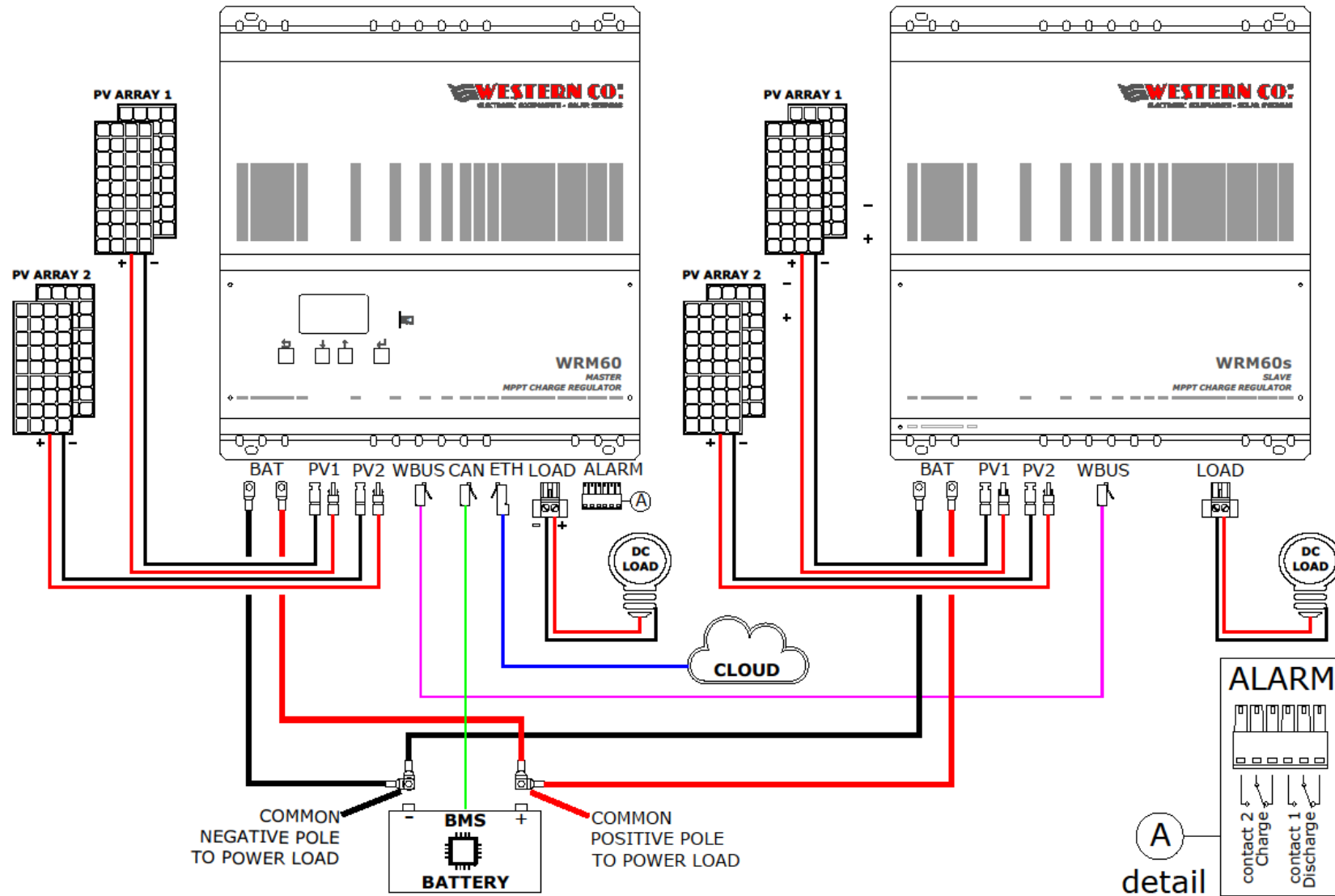

Fig.6 - Schema di collegamento WRM60 M - CB + WRM60 S

Piattaforma IoT di monitoraggio e controllo remoto

La serie WRM60/90, attraverso la connessione a internet e la tecnologia IoT, comunica con il server remoto e trasmette i dati di funzionamento. Registrandosi e facendo il login sull'interfaccia web client WRM MONITOR, è possibile interagire con il proprio impianto modificandone le impostazioni e, allo stesso tempo, monitorare il proprio sistema energetico. In particolare, l'utente ha accesso alle seguenti funzionalità:

- Monitoraggio dei dati inviati dal sistema in tempo reale: valori di potenza prodotta, assorbita/prelevata dalla batteria e consumata dal carico, lo stato di carica della batteria e eventuali stati di allarme.
- Visualizzazione di grafici, contatori e indicatori relativi alle statistiche del sistema: andamento di tutte le grandezze tipiche del sistema, quali tensioni, correnti e potenze. Possibilità di selezionare il periodo temporale di visualizzazione.
- Report degli eventi inerenti al sistema, quali allarmi o informazioni utili.
- Informazioni specifiche dell'impianto installato (tipo, capacità e tensione di batteria, versioni dei firmware dei dispositivi).



Fig.7 - WEB Client

Accesso al portale

La prima volta che si effettua l'accesso all'interfaccia WRM MONITOR è necessario registrarsi. La registrazione è effettuata al seguente link (valido anche per i successivi accessi).

<http://wrserver.western.it/signup>

È necessario inserire il proprio nome e l'indirizzo email, successivamente bisogna scegliere una password. A questo punto l'accesso alla propria dashboard si effettua cliccando su **HOME WRM MONITOR**.

Al primo accesso è necessario inserire nella casella "Select your Device Key", come mostrato in Fig.8 (qui sotto), l'identificativo KEY CODE del proprio WRM60/90 (es. 0123456789ABCDEF) che è riportato sull'etichetta sul lato del prodotto o sul MENU 7.4 del display (come descritto a pag.16). Una volta inserito il codice bisogna premere INVIO dalla tastiera. A questo punto è possibile monitorare il proprio sistema e navigare fra le varie funzionalità.

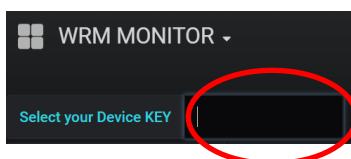

Fig.8 – Inserimento Key Code

Navigazione Menu:

La navigazione tra le varie videate è molto semplice e intuitiva. Il WRD ha due ambienti di visualizzazione (Fig.2):

- l'ambiente principale MAIN, composto da 6 videate dove si monitora il funzionamento del sistema;
- l'ambiente d'impostazione SETUP, composto da 6 videate + 5 in ADV. SETUP dove vengono impostati i setting per il funzionamento.

Nell'ambiente MAIN si usano i tasti Up/Down che permettono di scorrere le videate da 1.0 a 6.0, il tasto Enter fa accedere a eventuali sottomenu. Premendo contemporaneamente i tasti Up/Down per 1 sec. si accede all'ambiente SETUP. Qui, si ripete sempre con gli stessi tasti Up/Down, lo scorrimento delle videate da 7.0 a 7.5. Per tornare nell'ambiente Main si usa il tasto Esc premuto per 1 sec.

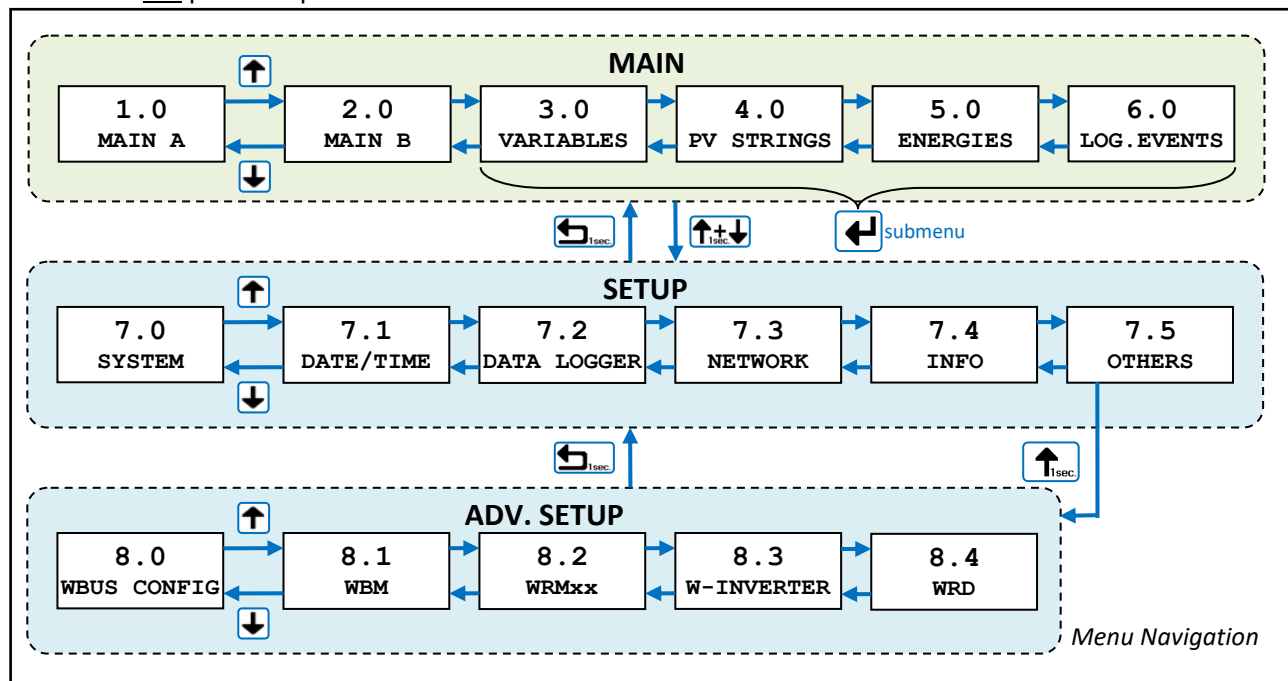

Fig.9 - Menu di navigazione

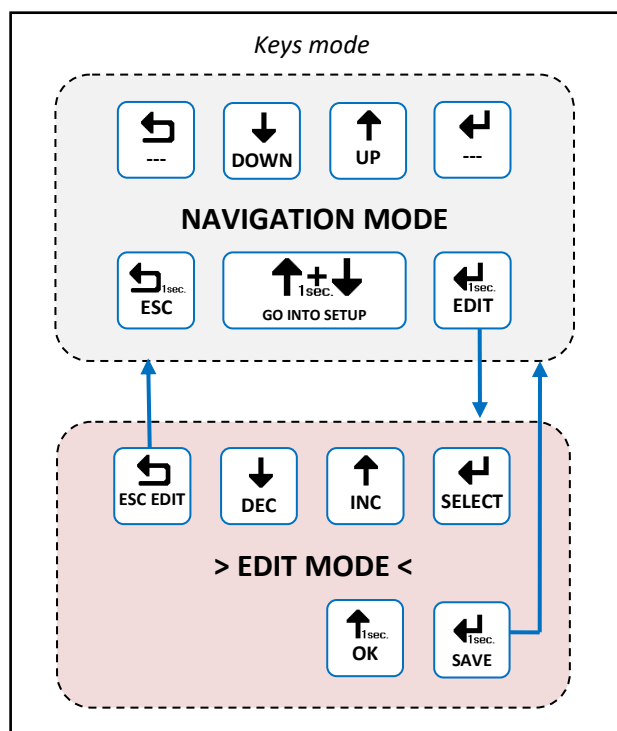
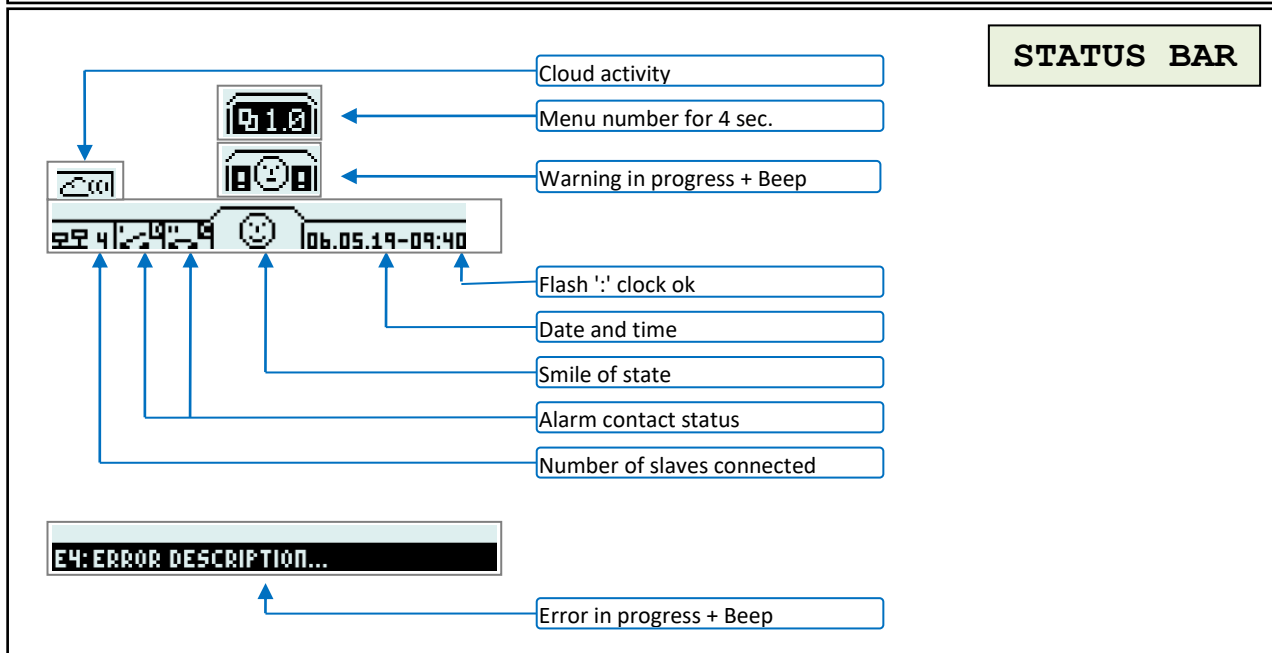
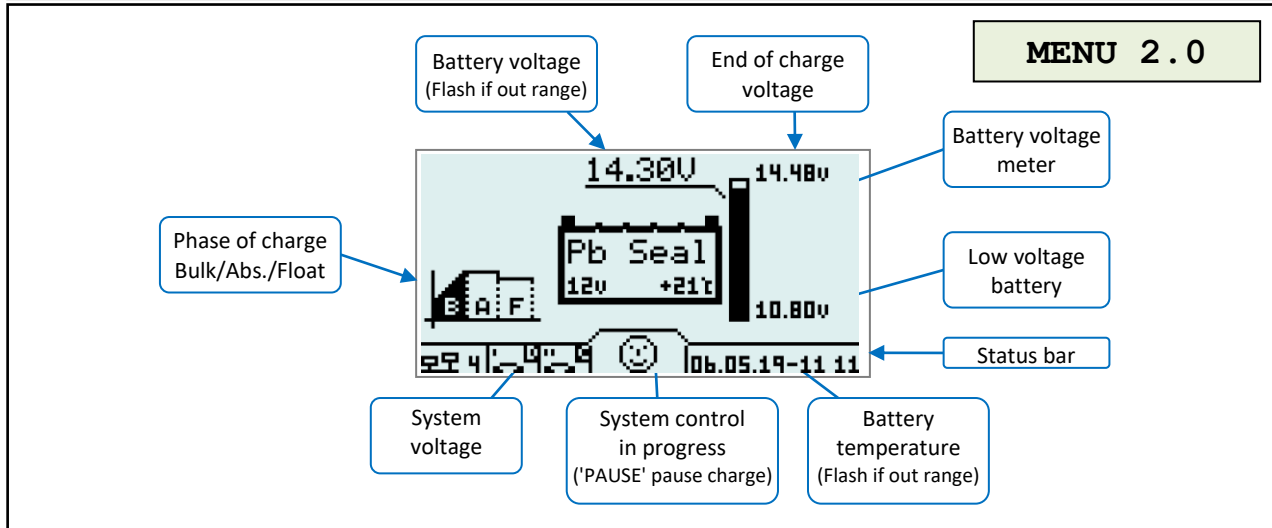
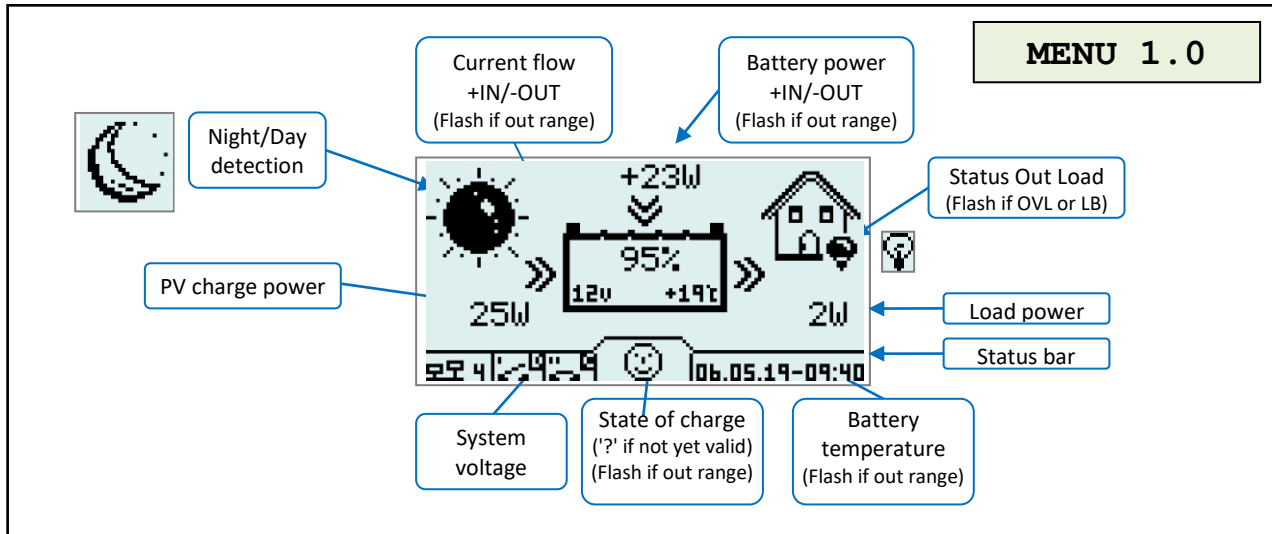

Fig.10 - Menu di editazione

È possibile entrare nella modalità di editazione (Fig.3), laddove è concesso, per modificare i parametri mantenendo premuto per 1 sec. il tasto Edit. L'entrata nella modalità di editazione è visibile sul display dalla presenza dei cursori sul parametro modificabile. Per la modifica si usano i tasti Inc/Dec, per passare su un altro parametro si usa il tasto Select mentre per uscire dalla modalità di Edit, **senza salvare le modifiche**, si usa il tasto Esc. Laddove i parametri da modificare sono organizzati in liste, i tasti Up/Down scorrono la lista oppure modificano il valore in base alla selezione. Per confermare alcune azioni sulle liste deve essere premuto per 1sec. il tasto OK. Per **salvare le modifiche** occorre mantenere premuto per 1 sec il tasto Save.

Videate Principali:

Configurazione WRM60/90 M



Configurazione WRM60/90 M

MENU 3.0

☀	V	A	W
☀	13.36	9.94	133
⬇️	4.20	4.20	56
⬆️	5.74	5.74	77
☰	3.0	VARIABLES	

Labels: Battery voltage (Flash if out range), PV charge current, PV charge power, Battery power IN/OUT (Flash if out range), Load power, Load current, Battery current IN/OUT (Flash if out range), n.Menu / Warning

MENU 4.0

PV input n.1

Ti+20°C	V _{pv}	A _{pv}	W _{pv}
☀	27.12	2.83	77
☀	27.20	2.62	71
☰	4.0	PV STRINGS	

Labels: internal temperature PV input hardware (Flash if over Temp.), PV "A" string, PV "B" string, n.Menu / Warning, PV string voltage, PV string current, PV string power, PV input displayed

MENU 5.0

☀	kWh	Start
☀	= 000.000	06/05/19
⬇️	= 000.000	06/05/19
⬆️	= 000.000	
🏠	= 000.000	
☰	5.0	ENERGIES

Labels: PV production counter from Reset, Battery input counter from Reset, Battery output counter from Reset, Consumption counter from Reset³, n.Menu / Warning, Date of Reset WRM counters, Date of Reset WBM counters

MENU 6.0

Info Warnings Error

List of: All Events

M.29-i-Cod.259-06/05/19-10:42.16		
M.30-E-Cod.541-06/05/19-10:42.17		
M.31-i-Cod.403-06/05/19-10:45.22		
M.32-W-Cod.152-06/05/19-10:48.40		
☰	6.0	LOG. EVENTS

Labels: Progressive number event (1..32), Oldest event occurring, Latest event occurring, n.Menu / Warning, Event list filter, Event type, Event code, Date and time event

Menu di Setup:

Configurazione WRM60/90 M

List displayed:	Value:	Settable value and descriptions:
MENU 7.0		
Settings:		
Batt.Type:	Pb Seal/	<p>WRM60/90 M-SB Master: Pb Flood 14.80@25°C / 29.60@25°C / 59.20@25°C : Setting to operate with Pb Flood type battery. Pb Seal/Gel 14.40@25°C/ 28.80@25°C / 57.60@25°C : Setting to operate with Pb Seal or Gel type battery. LiFePO4 <14.00..14.70V> <28.00..29.40V> <56.00..58.80V> fixed : Setting to operate with Lithium type battery with integrated BMS.</p> <p>WRM60/90 M-CB Master: LG Chem RESU %04.2fV fixed : Setting to operate with LG Chem RESU series battery PYLONTEC %04.2fV fixed : Setting to operate with PYLONTEC series battery (work in progress..)</p>
B.Capacity:	200Ah	<10..2000Ah> battery bank capacity, to compute SoC.
OFF disch.#1:	↓ 25%	<0%..ON disch> below this threshold, the ALARM output 1 is activated. Discharge OFF.
ON disch.#1:	↑ 40%	<OFF disch..100%> above this threshold, the ALARM output 1 is deactivated. Discharge ON.
OFF charge#2:	↑ 100%	<ON charge..100%> above this threshold, the ALARM output 2 is activated. Charge OFF.
ON charge#2:	↓ 90%	<0%..ON charge> below this threshold, the ALARM output 2 is deactivated. Charge ON.
Prog.Load:	OnSurplus	<p>24h/24h : LOAD output always active. <1..16h> : LOAD output active from sunset for the set hours. Only Night : LOAD output active only during the night. Only Day : LOAD output active only during the day. OnSurPlus : LOAD output active only during an energy surplus.</p>
LowB.Load:	11.12V	<10,8..12,56V> below this threshold, the LOAD output is activated.
<div style="border: 1px solid black; padding: 2px; display: flex; justify-content: space-between;"> 7.0 SYSTEM ⏪ </div>		

Configurazione WRM60/90 M

MENU 7.1

List displayed:	Value:	Settable value and descriptions:
Set Date Time: dd/mm/yy: 31/12/18 hh:mm:ss: 12:59.00 TimeZone: UTC +1	← <code><1..31>/<1..12>/<00..99></code> days/months/years ← <code><0..23>:<0..59></code> hours:minutes.seconds ← <code><-12..+13></code> site timezone	
7.1 DATE / TIME		

MENU 7.2

List displayed:	Value:	Settable value and descriptions:
Info & Setting: sample Time: 10min Info: --> NOT PRESENT Info: uSD CARD File SYS: FAT32 free space: 3772MB Info: Find WRD*.* WRDEVENT.LOG 27kB 01/02/12 01:23:45 WRDATA2.LOG 27kB 01/02/12 01:23:45 END LIST Info: SAMPLE EVENT 00:30	← OFF : Data logger disabled (uSD CARD ejectable) <code><1..30min></code> logger sampling time.	Logger information: --> : select the type of information to show. If there is no card show "NOT PRESENT", and no information is available. uSD CARD : read the type of file system (NONE, FAT12/16/32) and calculates the free space on the card. FIND WRD*.* : read and list the files one at a time by showing the name, size, and date of the last update. At the end shows "END LIST". SAMPLE EVENT : show the remaining time for the next sampling
7.2 DATA LOGGER		

Configurazione WRM60/90 M

MENU 7.3

List displayed:	Value:	Settable value and descriptions:
Item:	Value:	
CONNECTION	: OFF	← OFF; ON : Disable/Enable cloud connection to transfer data to the server.
Enable DHCP	: ON	← OFF; ON : Disable/Enable DHCP function.
1-IP Address	: 192	← <0..255> : set the device IP Address. <0..255> : " <0..255> : " <1..255> : " DHCP : set the Network Setup automatically (the other values will be ignored).
2-IP Address	: 168	
3-IP Address	: 100	
4-IP Address	: DHCP	
1-subNetMask	: 255	← <0..255> : set the subnet mask. <0..255> : " <0..255> : " <0..255> : "
2-subNetMask	: 255	
3-subNetMask	: 255	
4-subNetMask	: 000	
1-Gateway	: 255	← <0..255> : set the Gateway IP Address. <0..255> : " <0..255> : " <0..255> : "
2-Gateway	: 255	
3-Gateway	: 255	
4-Gateway	: 255	
1-prim.DNS	: 008	← <0..255> : set the primary DNS IP Address. <0..255> : " <0..255> : " <0..255> : "
2-prim.DNS	: 008	
3-prim.DNS	: 008	
4-prim.DNS	: 008	
1-secon.DNS	: 255	← <0..255> : set the secondary DNS IP Address. <0..255> : " <0..255> : " <0..255> : "
2-secon.DNS	: 255	
3-secon.DNS	: 255	
4-secon.DNS	: 255	
7.3 NETWORK		

Configurazione WRM60/90 M

List	Value:	Settable value and descriptions:	MENU 7.4
Network param. :			
status:	OFF-LINE	← OFF-LINE; ON-LINE : current status of cloud connection.	
IP :	192.168.100.067	← current device IP Address.	
sNM:	255.255.255.000	← current subnet mask.	
Gwy:	255.255.255.255	← current Gateway IP Address.	
DNS:	255.255.255.255	← current primary DNS IP Address.	
dns:	255.255.255.255	← current secondary DNS IP Address.	
MAC:	D880394F5632	← device MAC Address.	
KEY:	0123456789ABCDEF	← device KEY code.	
Device: rev.Fw:			
WRD	: 1.0	← firmware revision of the WRD device.	
WBM	: 1.0	← firmware revision of the WBM device.	
WRMxx	n.1: 1.0	← firmware revision of the WRMxx devices, from 1^ to 8^. (0.0 if device is not present)	
WRMxx	n.2: 1.0		
WRMxx	n.3: 0.0		
WRMxx	n.4: 0.0		
WRMxx	n.5: 0.0		
WRMxx	n.6: 0.0		
WRMxx	n.7: 0.0		
WRMxx	n.8: 0.0		
W-INVERTER	: 0.0	← firmware revision of the W-INVERTER device.	
7.4 SYSTEM INFO			

List displayed:	Value:	Settable value and descriptions:	MENU 7.5
Items:			
En.EvBeep:	ON	← OFF; ON : Disable/Enable sound alert.	
PAUSE Charge:	OFF	← OFF; ON : Pause the PV charge.	
Advanced Setup:	-->	← --> : Access to advanced setup menu 8.X.	
7.5 VARIOUS			

Configurazione WRM60/90 M

List displayed:	Value:	Settable value and descriptions:
MENU 8.0		
Device: Address:		
AutoConf: ---		RUN : starts the procedure to automatically identify the connected devices.
WBMonitor : 33		00; 33 : WBUS Address of the WBM device.
WRMxx n.1: 01		<0..32> : WBUS Address of the WRMxx devices, from 1^ to 8^. (00 if device is not present)
WRMxx n.2: 02		
WRMxx n.3: 00		
WRMxx n.4: 00		
WRMxx n.5: 00		
WRMxx n.6: 00		
WRMxx n.7: 00		
WRMxx n.8: 00		
W-INVERTER: 00		00; 34 : WBUS Address of the WI device.
8.0 WBUS CONFIG. ←		

Configurazione WRM60/90 M

List displayed:	Value:	Settable value and descriptions:
MENU 8.1		
WBM SETUP:		
Batt.Type:	Pb Seal/	<p>WRM60/90 M-SB Master:</p> <p>Pb Flood 14.80@25°C / 29.60@25°C / 59.20@25°C : Setting to operate with Pb Flood type battery.</p> <p>Pb Seal/Gel 14.40@25°C/ 28.80@25°C / 57.60@25°C : Setting to operate with Pb Seal or Gel type battery.</p> <p>LiFePO4 <14.00..14.70V> <28.00..29.40V> <56.00..58.80V> fixed : Setting to operate with Lithium type battery with BMS integrated.</p> <p>WRM60/90 M-CB Master:</p> <p>LG Chem RESU %04.2fv fixed : Setting to operate with LG Chem RESU series battery</p>
B.Capacity:	200Ah	<10..2000Ah> battery bank capacity, to compute SoC.
OFF disch.#1:	↓ 25%	<0%..ON disch> below this threshold, the ALARM output 1 is activated. Discharge OFF.
ON disch.#1:	↑ 40%	<OFF disch..100%> above this threshold, the ALARM output 1 is deactivated. Discharge ON.
OFF charge#2:	↑ 100%	<ON charge..100%> above this threshold, the ALARM output 2 is activated. Charge OFF.
ON charge#2:	↓ 90%	<0%..ON charge> below this threshold, the ALARM output 2 is deactivated. Charge ON.
UPDATE FW:	---	RUN : *CAUTION* starts the procedure to update the firmware in the WBM device. The firmware update file must be present in the USD card.
<div style="border: 1px solid black; padding: 2px; display: flex; justify-content: space-between;"> 8.1 WBM ⏪ ⏩ </div>		

Configurazione WRM60/90 M

List displayed:	Value:	Settable value and descriptions:	MENU 8.2
WRM30 n.1 SETUP:		<1..8> select the WRM30 to edit.	
VEoCharge: 14.40V		Set the battery charge voltage: Pb Flood 14.80@25°C / 29.60@25°C / 59.20@25°C : Setting to operate with Pb Flood type battery. Pb Seal/Gel 14.40@25°C / 28.80@25°C / 57.60@25°C : Setting to operate with Pb Seal or Gel type battery. LiFePO4 <14.00..14.70V> <28.00..29.40V> <56.00..58.80V> fixed : Setting to operate with Lithium type battery with integrated BMS.	
VLowBatte: 12.56V		<12,00..12,56V> / <24,00..25,12V> / <48,00..50,24V> : below this threshold, the WRM30 goes into Low Battery status and deactivates the LOAD.	
VEndLBatt: auto		auto (VEoC-0,2/0,4/0,8V); <12,72..13,68V> / <25,44..27,36V> / <50,88..54,72V> : above this threshold, the WRM30 goes out Low Battery status and reactivates the LOAD.	
Prog.Load: 16hour		24h/24h : LOAD always active. <1..16h> : LOAD active from sunset for the set hours. Only Night : LOAD active only during the night. Only Day : LOAD active only during the day. OnSurPlus : LOAD active only during an energy surplus.	
VnightThd: 2.00V		2,00V; 3,28V; 4,56V; 5,84V : below this threshold, the WRM30 detect the sunset.	
MPPT algo: auto		auto; parall.; indep. : mode in which the MPPT algorithm considers the two channels.	
HrToFloat: 1hour		<1..8h> : time in Absorption phase before moving to Float phase.	
UPDATE FW: ---		RUN : *CAUTION* starts the procedure to update the firmware in the WBM device. The firmware update file must be present in the USD card.	
8.2 WRM30			

List displayed:	Value:	Settable value and descriptions:	MENU 8.3
WI SETUP:			
not present			
8.3 W-INVERTER			

Configurazione WRM60/90

List displayed:	Value:	Settable value and descriptions:	MENU 8.3
WRD SETUP:			
Oper.Mode: MONITOR		MONITOR; CONTROLLER : Operating Mode: Monitor/Controller	
Backlight: auto OFF		auto OFF; always ON : Backlight LCD: Auto power-OFF/ always ON	
RESET: RUN		RUN : Reset the WRD device.	
UPDATE FW: RUN		RUN : *CAUTION* starts the procedure to update the firmware in the WRD device. The firmware update file must be present in the USD card. To start the procedure press both ↑ and ↓ keys.	
Tech. Menu Psw: 00		<0..FF> password to access the Technical Menu. *CAUTION* Technical Menu is reserved for factory checks.	

Caratteristiche elettriche

Parameter	Symb.	WRM60 M-SB Master	WRM60 M-CB Master	WRM60 S Slave	WRM90 M-SB Master	WRM90 M-CB Master	WRM90 S Slave	U.M.
Nominal battery voltage		12 / 24 / 48 autodetect						(V)
Battery voltage range (12/24/48V)	V _{bat}	10..16/ 20..32 / 40..64						(V)
Max charge current ¹	I _{ch}	60			90			(A)
Max charge power (12/24/48V)	P _{ch}	900 / 1800 / 3600			1350 / 2700 / 5400			(W)
Max open circuit voltage of PV string	V _{oc}	180						(V)
Max short circuit current of each PV string input	I _{sc_n}	26						(A)
Independent MPPT PV string input	PV _n	2			3			
Max power of each PV string input (12/24/48V)	P _{pv_n}	450 / 900 / 1800						(W)
Self consumption	P _q	1,0			1,2			(W)
Operating temperature	T _{amb}	-10..+40						(°C)
Max power dissipated (12/24/48V)	P _{loss}	80 / 112 / 132			120 / 168 / 198			(W)
Efficiency @ 60A (12/24/48V)	η	90 ÷ 92 / 93,5 ÷ 95,2 / 96,0 ÷ 97,2						(%)
Parallel slave operation		controlled via W-BUS						
Weight		6,275			8,75			(kg)
Dimension		370 x 386 x 113			545 x 386 x 113			(mm)
Degree of protection		IP20						
		WRM60/90 M-CB Master		WRM60/90 M-SB Master		WRM60/90 S Slave		
Smart Battery profiles		- LG Chem RESU 48V		-Generic profiles (Flood, Seal/Gel, Li)		sent from Master via W-BUS		
Working parameters		sent from BMS via CAN-BUS		sent from WBM via W-BUS				
Charge algorithm ²		multistage: Bulk / Absorption / Float						
Generic profiles				Pb-Flood	Pb-Seal-Gel	Lithium		
End of charge voltage @ 25°C (12V/24/48V)	V _{EoC_12} V _{EoC_24} V _{EoC_48}			14,8 29,6 59,2	14,4 28,8 57,6	14,0..14,7 28,0..29,4 56,0..58,8	parameters sent from Master via W-BUS	(V)
V _{EoC} temperature compensation ³ (12/24/48V)	V _{tadj}			-24 / -48 / -96				(mV/°C)
Float voltage (12/24/48V)	V _{fit}			V _{EoC} - (0,6 / -1,2 / -2,4)				(V)
Absorption time to float state	T _{abs}			4				(h)
Output LOAD topology ⁴		open drain						
Output LOAD voltage	V _{LOAD}	V _{batt}						(V)
Output LOAD current	I _{LOAD}	15						(A)
Output ALARM topology		relè		relè				
Output ALARM current	I _{ALA}	60Vdc 5A		60Vdc 0,1A				
Battery connection		terminal M8						
Battery cable		pair of R/N 25mm ² 1,8m with ring terminal Ø8 (supplied)						
PV string input connection		2/3 pairs of M/F MC4 (connector supplied)						
Solar cable section for MC4 connectors		4/6mm ²						
Cable section for output LOAD connector		2,5mm ² (connector supplied)						
Cable section for output ALARM connector		1,5mm ² (connector supplied)		0,5mm ² 1,8m (cable supplied)				
Internet cable connector		RJ45 (cable supplied)						
Control bus interface connector		RJ11 (cable supplied)						
Control bus interface topology		W-BUS						
Battery bus interface connector		RJ45 (cable supplied)		RJ11 (cable supplied)				
Battery bus interface topology		CAN		W-BUS				
External shunt device				WBM-Shunt (supplied)				
Battery connector on WBM-Shunt (negative)				hole Ø7 (18x20mm) (isolator + ring terminal supplied)				
Supply cable on WBM-Shunt				1mm ² 1,8m with ring terminal Ø8 (supplied)				
Electrical protection		Battery reverse polarity, temperature derating, overload.						

Tab.2 - Caratteristiche elettriche

¹The maximum charging current is limited to 30A for each PV input.

²With the Li program, the Float stage does not exist.

³With the Li program, the VEoC is not compensated in temperature.

⁴Positive in common.

Grafici

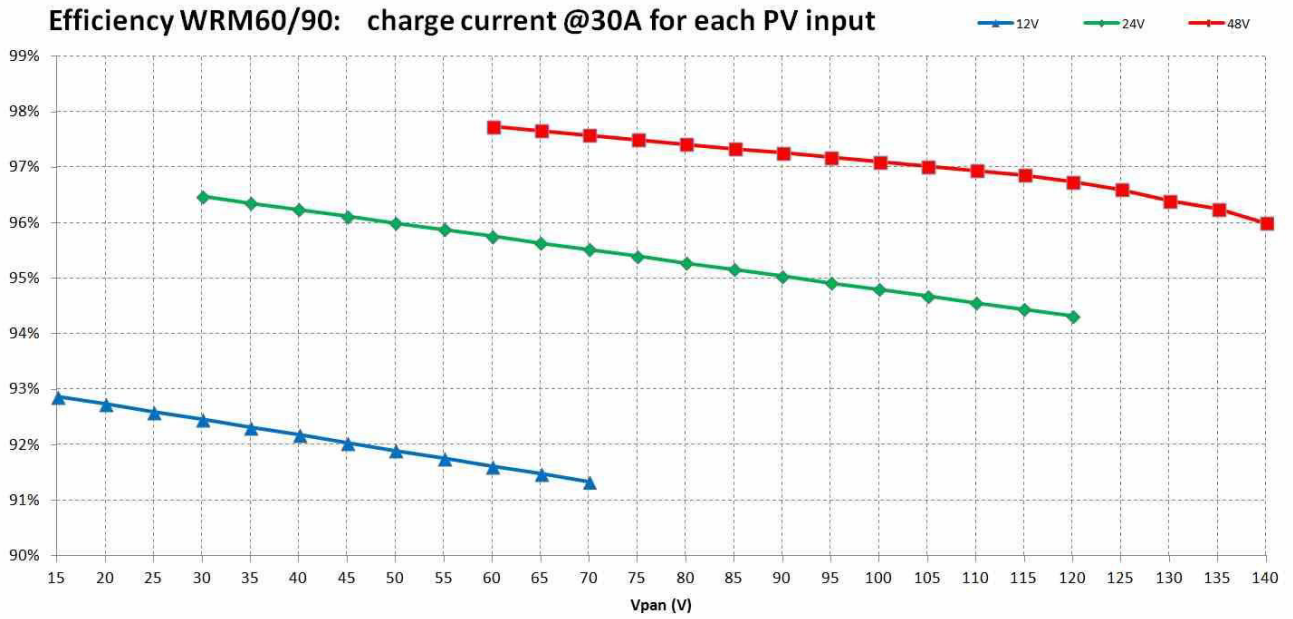

Fig.11 - Grafico Efficienza

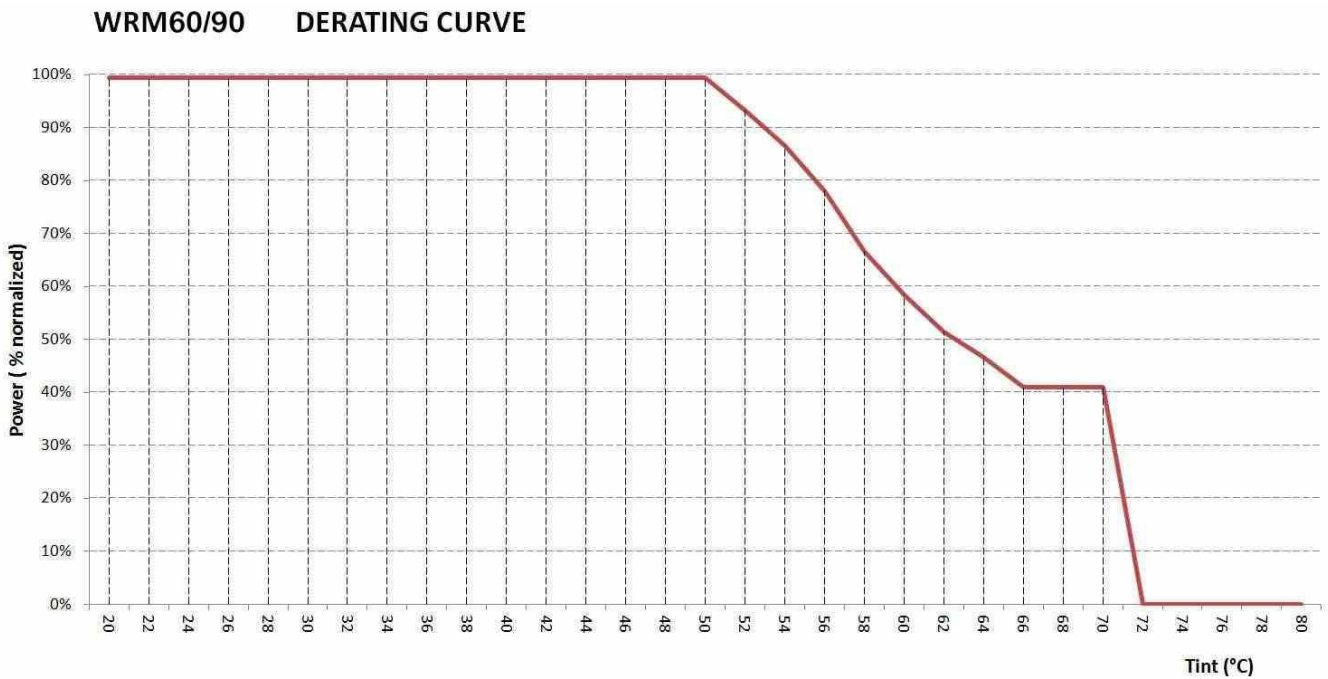

Fig.12 - Grafico Temperature Derating

Dimensioni

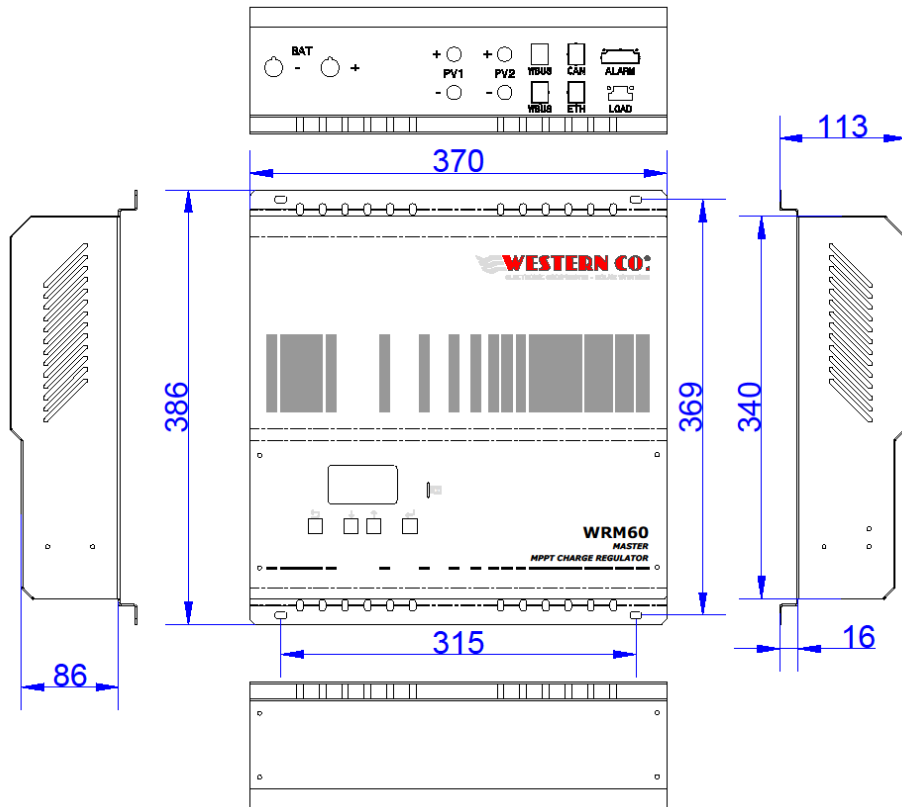

Fig.13 - Dimensioni meccaniche WRM60

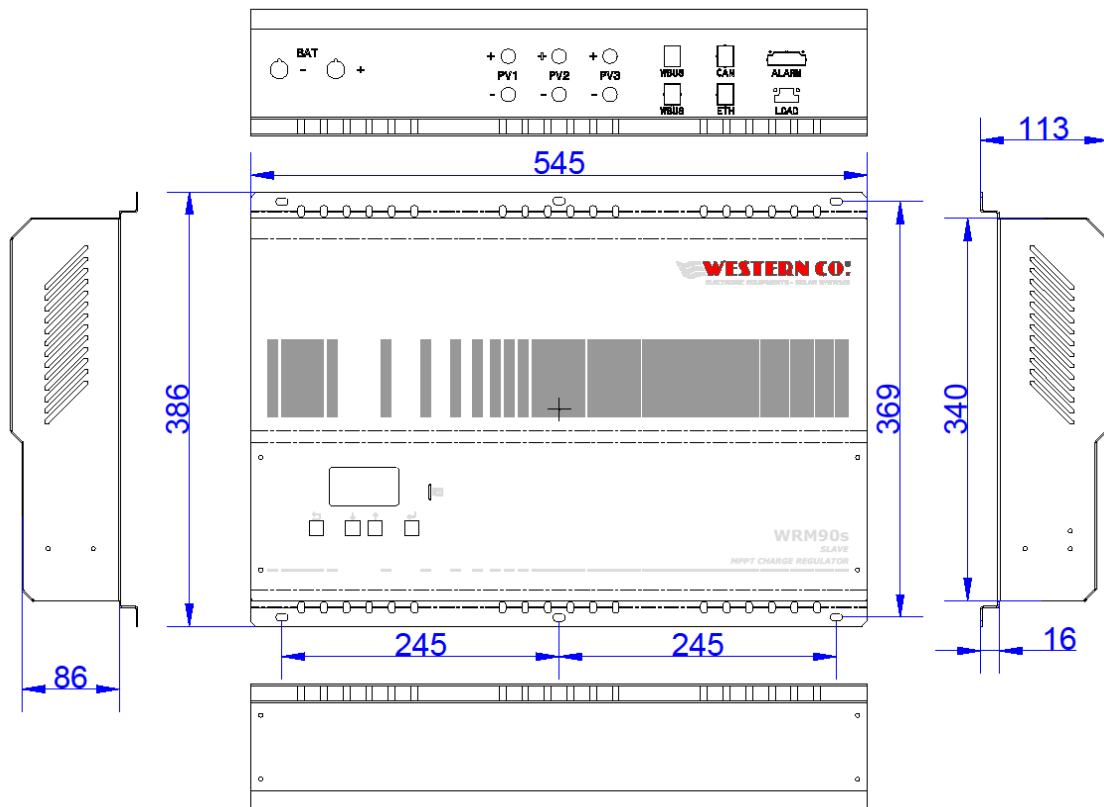

Fig.14 - Dimensioni meccaniche WRM90

Garanzia di legge

Western CO. Srl garantisce la buona qualità e la buona costruzione dei Prodotti obbligandosi, durante il periodo di garanzia di 5 (cinque) anni, a riparare o sostituire a sua sola discrezione, gratuitamente, quelle parti che, per cattiva qualità del materiale o per difetto di lavorazione si dimostrassero difettose.

Il prodotto difettoso dovrà essere rispedito alla Western CO. Srl o a società delegata dalla Western CO. Srl a fare assistenza sul prodotto, a spese del cliente, assieme ad una copia della fattura di vendita, sia per la riparazione che la sostituzione garantita. I costi di re-installazione del materiale saranno a carico del cliente.

La Western CO. Srl sosterrà le spese di re spedizione del prodotto riparato o sostituito.

Il tutto come indicato sulle condizioni di garanzie disponibili alla pagina: <http://www.western.it/garanzia/>

La garanzia non copre i Prodotti che, in base a nostra discrezione, risultino difettosi a causa di naturale logoramento, che presentino guasti causati da imperizia o negligenza del cliente, da imperfetta installazione, da manomissioni o interventi diversi dalle istruzioni da noi fornite .

La garanzia decade altresì in caso di danni derivanti da:

-trasporto e/o cattiva conservazione del prodotto.

-causa di forza maggiore o eventi catastrofici (gelo per temperature inferiori a -20°C, incendio, inondazioni, fulmini, atti vandalici, ecc ...).

Tutte le sopraccitate garanzie sono il solo ed esclusivo accordo che soprassedie ogni altra proposta o accordo verbale o scritto e ogni altra comunicazione fatta tra il produttore e l'acquirente in rispetto a quanto sopra.

Per qualsiasi controversia il Foro competente è Ascoli Piceno.

Smaltimento dei rifiuti

La Western CO. in qualità di produttore del dispositivo elettrico descritto nel presente manuale, ed in conformità al D.L 25/07/05 n 151, informa l'acquirente che questo prodotto, una volta dismesso, deve essere consegnato ad un centro di raccolta autorizzato oppure, in caso di acquisto di apparecchiatura equivalente può essere riconsegnato a titolo gratuito al distributore della apparecchiatura nuova.

Le sanzioni per chi abusivamente si libera di un rifiuto elettronico saranno applicate dalle singole amministrazioni comunali.



SEHM SERIES - WRM60/WRM90 - IoT SMART CHARGE CONTROLLER 12/24/48V MPPT 60/90A

Models	Description
WRM60 M - SB	IoT Smart Master C.C. MPPT 60A Shunt Battery Monitor
WRM90 M - SB	IoT Smart Master C.C. MPPT 90A Shunt Battery Monitor
WRM60 M - CB	IoT Smart Master C.C. MPPT 60A CAN Battery Monitor
WRM90 M - CB	IoT Smart Master C.C. MPPT 90A CAN Battery Monitor
WRM60 S	IoT Smart Slave C.C. MPPT 60A 12/24/48V
WRM90 S	IoT Smart Slave C.C. MPPT 90A 12/24/48V



The WRM60/90 series includes 60/90A MPPT controllers for 12/24/48V systems, with 2/3 independent PV inputs and a Battery Monitor for Lead or Lithium batteries. Thanks to IoT technology and standard Internet connection, the devices allow both monitoring and remote configuration. They are particularly suitable for large-scale professional photovoltaic systems.

The **WRM60/90 M - CB** (Master - CAN Battery) is designed for lithium batteries with integrated BMS and CAN-BUS interface. The **WRM60/90 M - SB** (Master - Shunt Battery), however, has its own Battery Monitor **WBM** that manages to control the energy flows of the battery by communicating with the **WBUS**. The **WBUS** is a proprietary control bus to communicate with the various compatible devices, able to access all the parameters both for the display and for the management of the control functions.

The WRM60/90 series is part of the **WESTERN WRD SYSTEM**: a flexible and advanced stand-alone system, with data monitoring and remote control from the Internet, through a cloud platform. The system is modular as it is possible to add to the system **WRM60/90 S** (Slave) to get charge powers up to 14kW.

The simple user interface, with 128x64 display and 4 buttons, allows an immediate visualization of all the parameters: powers, voltages, charge and PV string currents, energy meters, data logger and events.

The two versions of **the WRM60/90 M** (SB and CB) allow the intelligent activation of loads connected to the system for efficient battery management.

The logger data is stored in the removable μ SD. Through the Internet connection is possible to connect to the cloud **WRM MONITOR** for monitoring and remote control of your system.

- **Battery voltage: 12/24/48V**
- **Autodetect 12/24/48V**
- **2/3 independent MPPT charging channels**
- **Maximum PV power**
 - **900/1350W..3600W @ 12V**
 - **1800/2700W..7200W @ 24V**
 - **3600/5400W..14400W @ 48V**
- **Max Voc voltage on PV modules 180V**
- **Compatible with lithium-ion batteries, LiFePO4, Pb Gel/AGM**
- **Profile management for smart battery**
- **Management of the State of Charge**
- **Internet connection**
- **CLOUD IoT technology**
- **Remote monitoring and management in the cloud**
- **WBUS Interface**
- **Data logger on extractable μ SD**
- **Backlighted LCD and menu navigation with 4 buttons**
- **Anti-reverse protection**
- **Over-Temperature protection**
- **Reverse battery polarity protection**
- **Overload protection on Load output**
- **Derating curve**
- **Integrates the WESTERN WRD SYSTEM**
- **IP20 Metallic box**
- **24mmq battery cables**
- **MC4 module connections**
- **Removable terminals on ALARM and LOAD outputs**

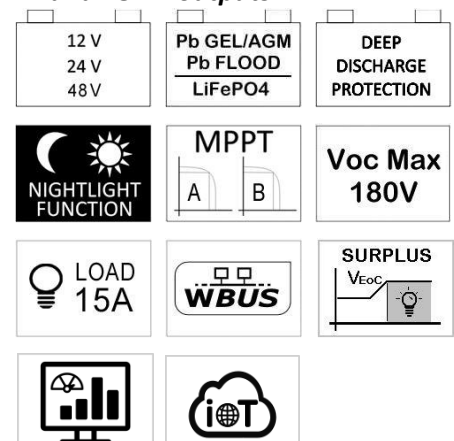

General description

The **WRM60/90 M - SB** is used in a stand-alone system with Pb Seal/Gel or Flood battery type or with Lithium batteries with VEoC included in the range¹ and that, despite having an integrated BMS, they do not have CAN communication. The battery monitor **WBM** provides for the measurement of battery energy input and output, as well as its management (see WBM manual for more details).

The **WRM60/90 M - CB** it is used in a stand-alone system with a Smart battery type (equipped with CAN communication) included in the compatible profiles¹.

WESTERN WRD SYSTEM

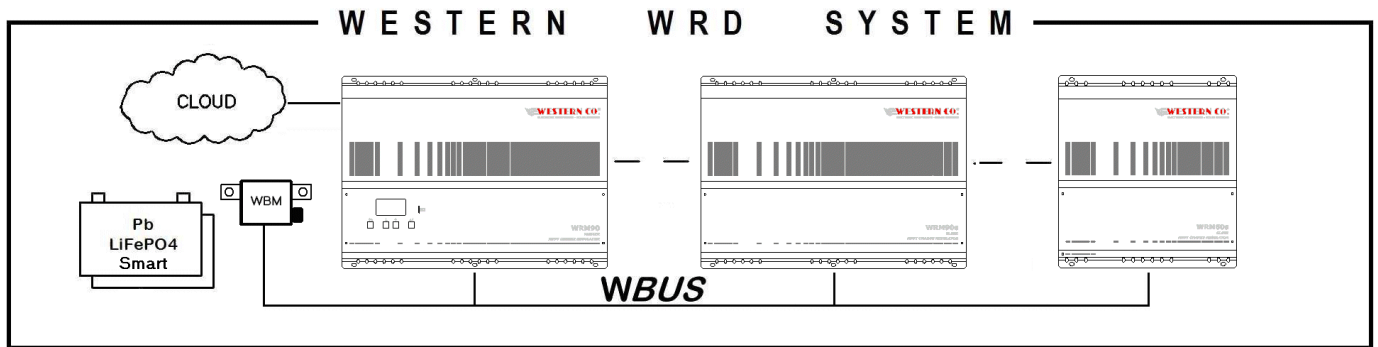

Pic.1 - WESTERN WRD SYSTEM

The **WESTERN WRD SYSTEM** is a modular stand-alone system, composed of a **WRM60/90 M** (Master) and one or more **WRM60/90 S** (Slave) to get charge powers up to 14kW. The Master is the coordinator of the system: dynamically modifies some parameters in order to optimize the energy management of the entire system and to ensure that the battery parameters are respected. The system allows data monitoring and remote control from the Internet, through a cloud platform.

Pic.2 shows the permitted Master/Slave combinations for the series **WRM60/90**. Obviously the power managed depends on the 12/24/48V system voltage (as shown in Tab.1)

POSSIBLE COMBINATIONS	Charging current (A)	Maximum PV input power of the system (kW)		
		12V system voltage	24V system voltage	48V system voltage
1	60	0.9	1.8	3.6
2	90	1.3	2.7	5.4
3	120	1.8	3.6	7.2
4-5	150	2.2	4.5	9
6	180	2.7	5.4	10.8
7	240	3.6	7.2	14.4

Tab.1 - Permitted Master / Slave combinations

¹ See Tab.2 - Electrical features under the heading Battery Profiles and End of Charge Voltage.

Permitted Master / Slave combinations

1
2
3
4
5
6
7

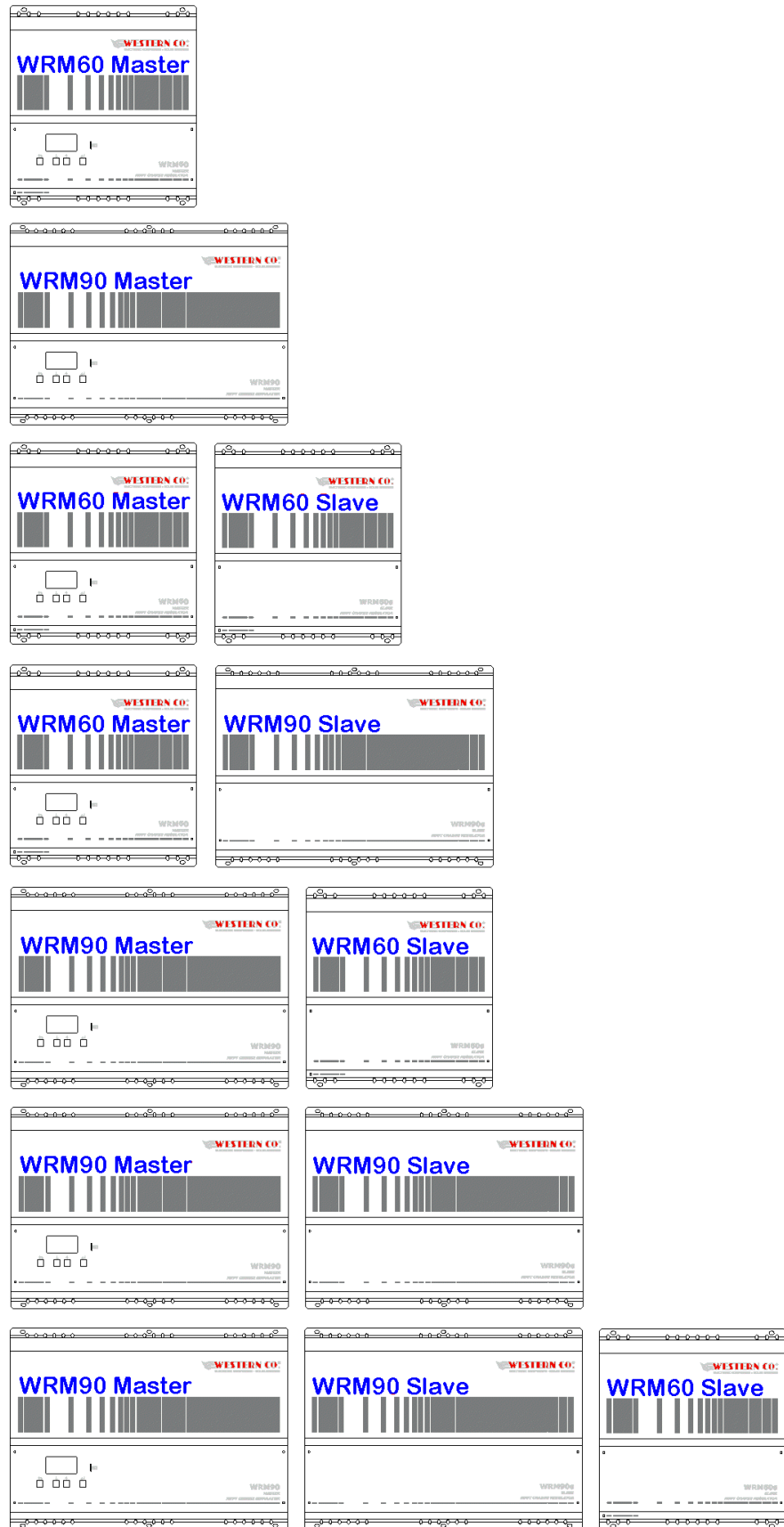

Pic.2 - Permitted Master / Slave combinations

Connections and installation

In *Pic.4 and 6* are respectively shown the system links for the versions **WRM60 M-SB** and **WRM60 M-CB**. The illustrated example employs a Master and a Slave, in case more Slaves are used it is simply necessary to replicate the connections for each of them, while with the Master only it is necessary to neglect the connections of the Slave. For the models **WRM90** apply the same scheme, only the connection for the third module string is added: **PV3**.



The electrical system is the responsibility of the installer, it must be implemented respecting all the safety criteria and inserting the appropriate protections.

Installation procedure:

1. Install the WRM60/90 in a dry place, use the two hooked dowel to hang it on the wall and the others provided to complete the fixing.
2. Make all connections. For the **WRM60/90-SB**, which also provides for connection of the WBM, see *Pic.4 and Pic.5*. For the **WRM60/90-CB** see *Pic.6*.²
 - **At the first turning on it is strongly recommended to activate the system by excluding the photovoltaic strings and any loads. After having set the correct battery profile (following point) and checked that the system does not signal errors, the photovoltaic strings can be connected, thus checking the charging parameters. Finally the loads can be activated.**
3. Now run the system configuration settings that will be required.
 - In the menu: **7.1 DATE / TIME** you set the system clock and the time zone (Timezone). It is important to correctly set the last parameter with the Timezone of the site where the system is located, so that the remote clock can be updated correctly.
 - At the menu: **7.0 SYSTEM** you make system settings. **The correct profile must be selected, corresponding to the battery features** (an incorrect choice could lead over time to damage the battery itself).
 - Set the correct battery capacity in Ah, so that the WBM can correctly calculate the State of Charge (%) of the Battery (not required in the WRM-CB version).
 - Set the thresholds for the two contacts controlled according to the State of Charge (%) of the Battery. The *Discharge* contact can be exploited to control a device capable of disabling the load, thus determining the maximum discharge depth within which the battery will cycle. This contact also intervenes in case of protections: overcurrent, overtemperature and undervoltage. With the *Charge* contact, normally, is controlled a device capable of disabling the charge as it intervenes in the event of protections: overcurrent, overtemperature and overvoltage. Setting the thresholds for the *Charge* contact it can also be controlled according to the SoC in case some applications require it. Considering that the charge is performed by the WRM60/90 and is already controlled through the WBUS, normally it is not necessary to take advantage of the *Charge* contact.
 - Select appropriately the setting of the *Load* output. The *Load* output can be exploited with setting '*Surplus*' to control or directly feed a load when the battery is charged and there is still energy from the PV modules so we have an excess of energy that in this way can be re-used.
 - Set the Low Battery threshold for the output *Load*.
4. Connect the photovoltaic strings.
5. Check the entire functioning by scrolling the screens.
6. Connect the loads.

² for the battery cables there are two cable fasteners, see *Pic.3*

- The loads, for example an inverter, must be connected directly to the battery using the WBM terminal (if present) as a common negative.
7. Further setup to be verified after the first start are:
- In the menu: **7.2 DATA LOGGER** to enable the data logger by setting the minutes for the sampling parameters: 10min. is the default value (enabled). Here you can also request information regarding the μ SD.
 - In the menu: **7.3 NETWORK** can be set the network parameters. The DHCP function is set by default, which automatically retrieves the necessary values. Here it is possible to enable or disable the connection to the remote server (default ON).
 - In the menu: **7.4 SYSTEM INFO** you can check, at the first item, the connection status.

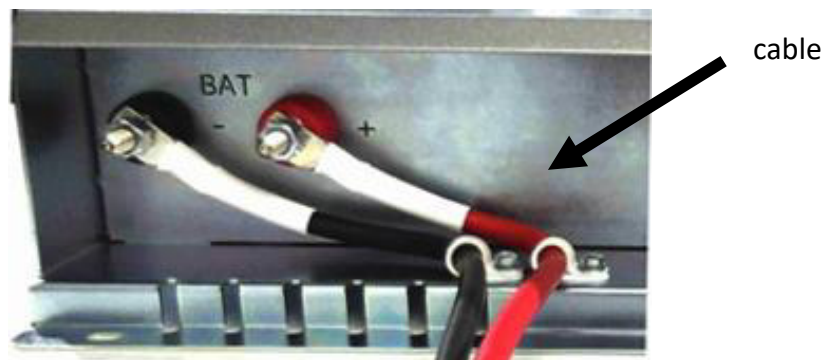

Pic.3 - Wiring of battery cables

Turn-off procedure:

To turn off the system it may not be sufficient to disconnect the battery, in fact, if the photovoltaic energy is sufficient to power the loads, the system remains in use.

For this reason it is necessary to follow the following procedure:

1. Deactivate the loads.
2. Deactivate all the photovoltaic inputs, with switch-disconnector, or using the function of Menu 7.5 -> PAUSE Charge = ON.
3. Deactivate the battery (with switch-disconnector or disconnecting the positive pole).

Wiring diagram WRM60 M - SB + WRM60 S

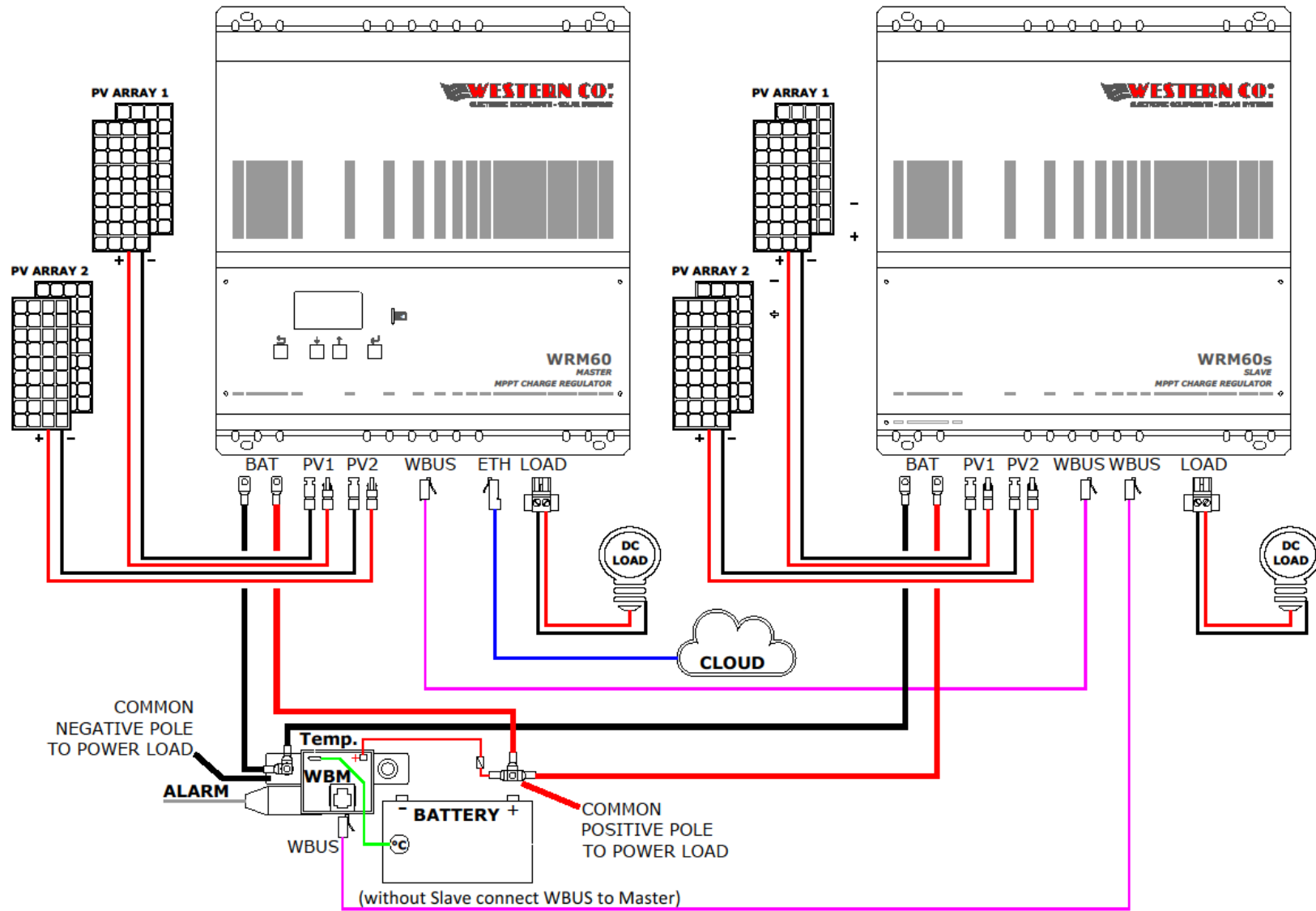

Pic.4 - Wiring diagram WRM60 M - SB + WRM60 S

WBM connection diagram

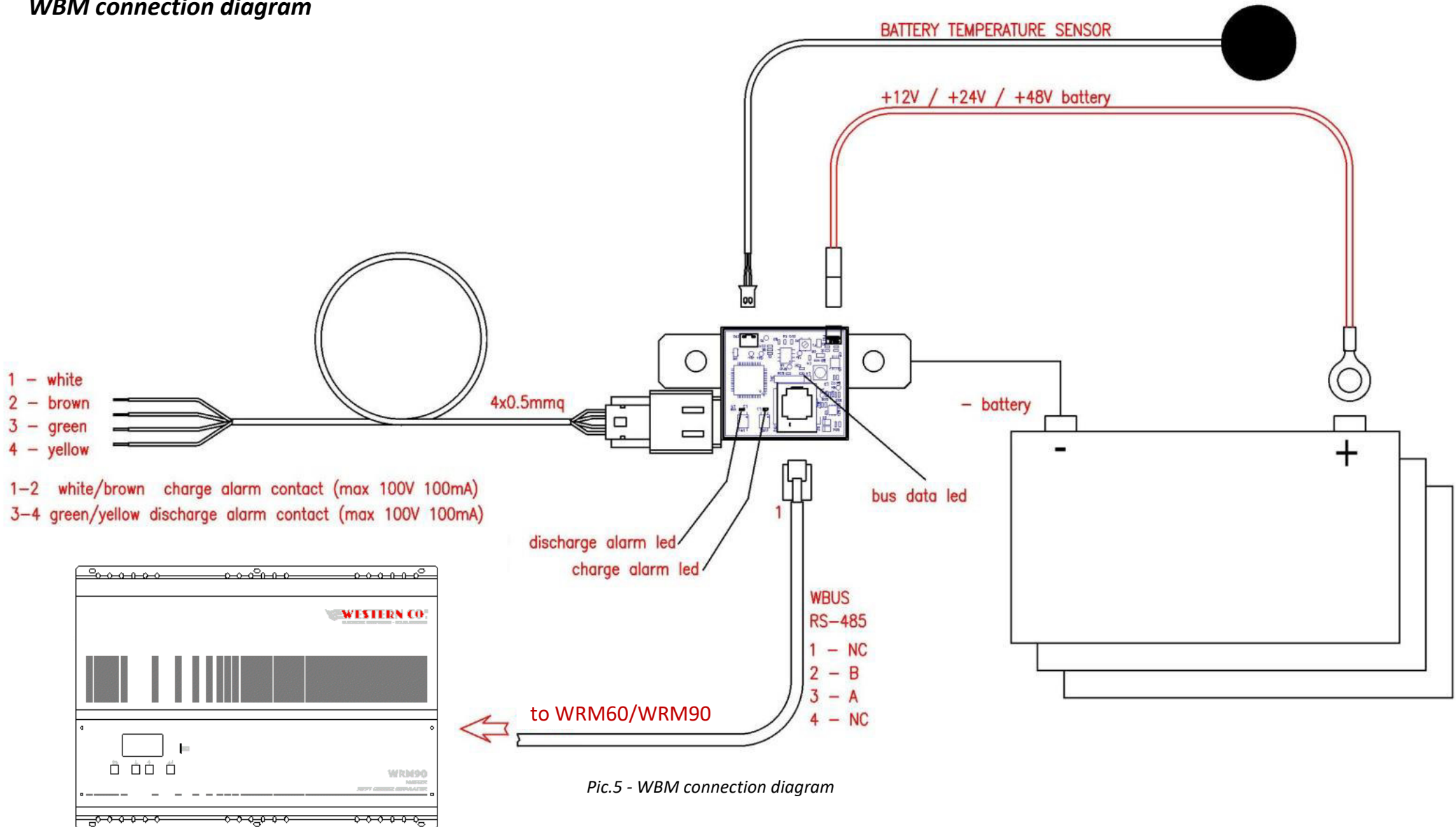

Pic.5 - WBM connection diagram

Wiring diagram WRM60 M - SB + WRM60 S

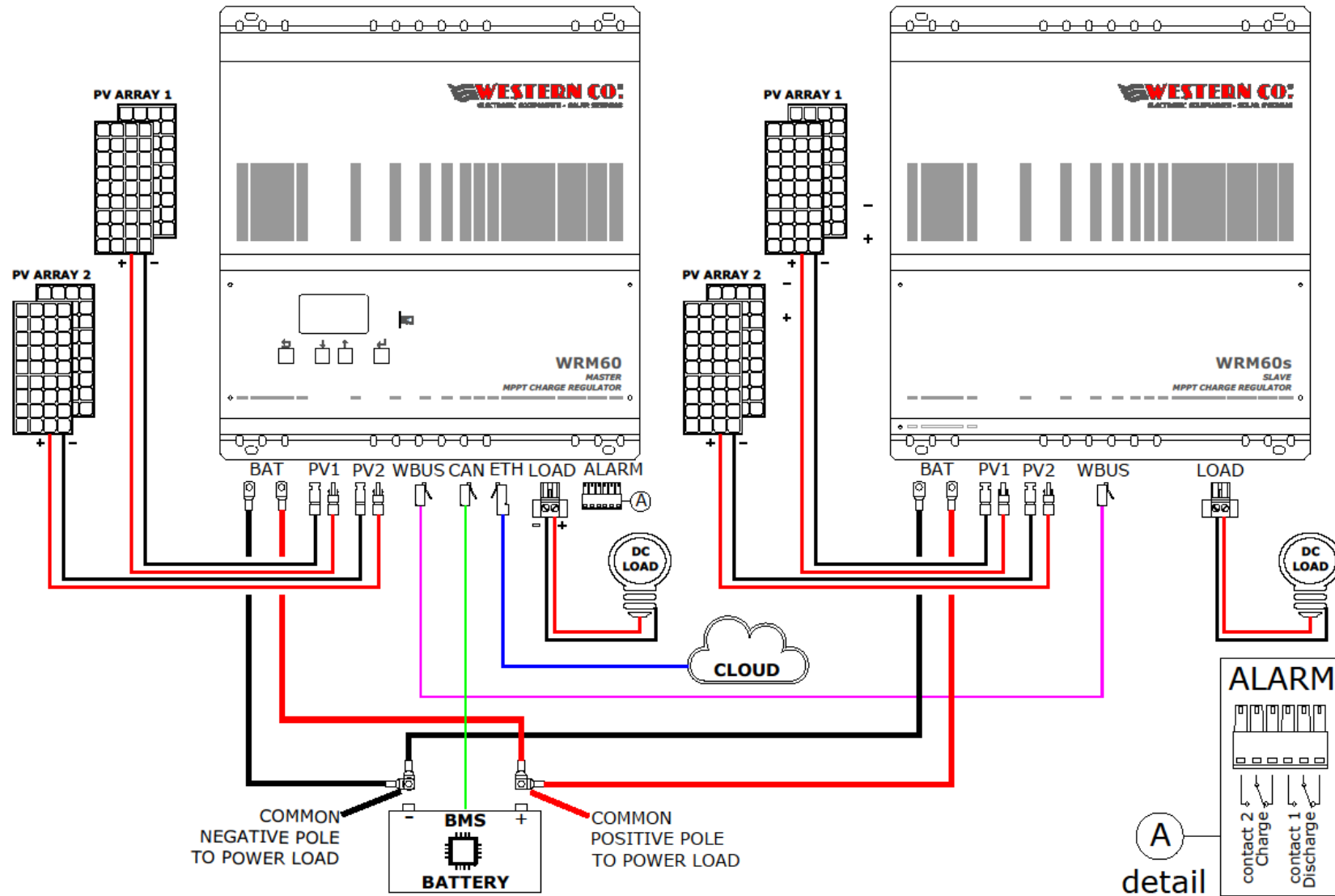

Pic.6 - Wiring diagram WRM60 M - SB + WRM60 S

IoT platform for monitoring and remote control

The WRM60/90 series, through the Internet connection and IoT technology, communicates with the remote server and transmits operating data. By registering and logging into the WRM MONITOR client web interface, it is possible to interact with the system by changing its settings and, at the same time, monitor its own energy system.

In particular, the user has access to the following features:

- Monitoring of the data sent by the system in real time: values of power produced, absorbed/taken from the battery and consumed by the load, the state of charge of the battery and any alarm status.
- Visualization of graphs, counters and indicators related to system statistics: trend of all the typical values of the system, such as voltages, currents and powers. Possibility to select the display time period.
- Reports of events related to the system, such as alarms or useful information.
- Specific information of the system installed (type, capacity and battery voltage, device firmware versions).



Pic.7 - WEB Client

Access to portal

The first time you log in to the WRM MONITOR interface, you need to register. Registration is carried out at the following link (also valid for subsequent accesses).

<http://wrdsrver.western.it/signup>

You need to enter your name and email address, then you have to choose a password.

At this point, access to your dashboard is done by clicking on **HOME WRM MONITOR**

When you first log in, you must enter the "Select your Device Key" box, as shown in *Pic.8* (below), the KEY CODE identifier of your WRM60 / 90 (e.g. 0123456789ABCDEF) which is written on the label on the side of the product or on the MENU 7.4 of the display (as described at *page 16*). Once the code is inserted, press ENTER from the keyboard. At this point you can monitor your system and navigate through the various features.

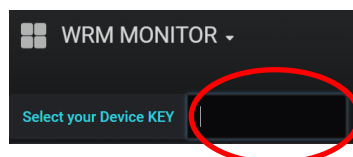

Pic.8 - Key Code entry

Menu Navigation

Navigating through the various screens is very simple and intuitive. The display has two viewing environments (*Pic.9*):

- the main environment MAIN, consisting of six screens where the operation of the system is monitored;
- the setting environment consisting of six screens SETUP, plus four in ADV. SETUP where the settings for operation are set.

In the environment MAIN only the Up/Down buttons are used to scroll through the screens from 1.0 to 6.0, the Enter key allows access to any submenus. Pressing the buttons simultaneously Up/Down for 1 sec. you access the SETUP environment. Also in this section, the Up/Down buttons allow the scrolling of screens from 7.0 to 7.5. To return to the MAIN environment the used button is Esc pressed for 1 sec.

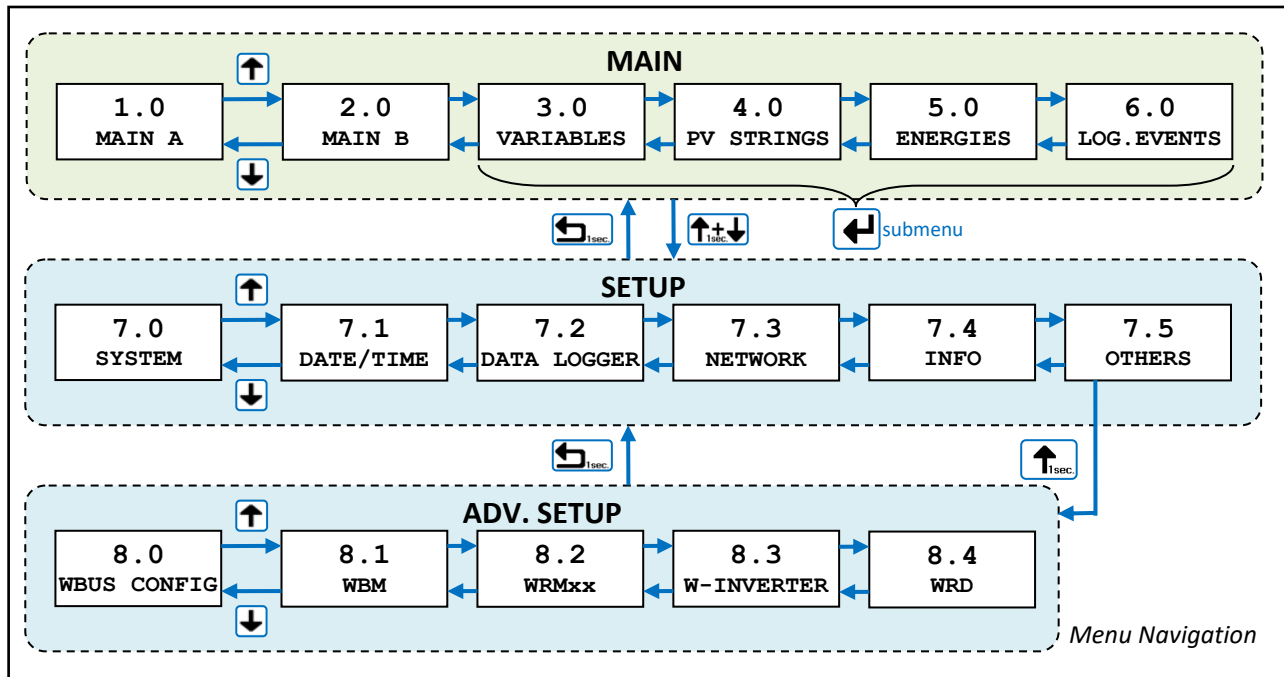

Pic.9 - Navigation menu

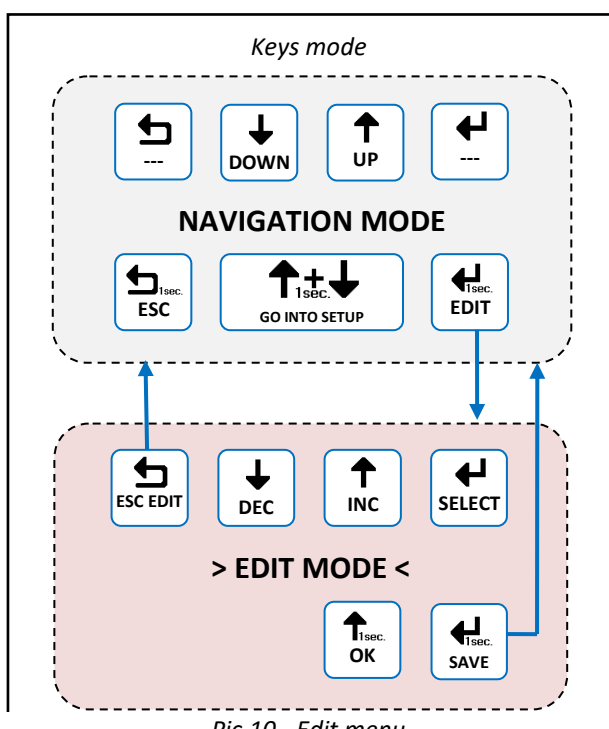

Pic.10 - Edit menu

It is possible to enter the editing mode (*Pic. 9*), where it is allowed, to modify the parameters by keeping pressed the Edit button for 1 sec. Entry into the editing mode is visible on the display by the presence of the cursors on the modifiable parameter. For editing use the Inc/Dec buttons. To switch to another parameter, use the button Select while to exit the Edit mode, **without saving the changes**, the Esc button is used. Where the parameters to be modified are organized in lists, the buttons Up/Down scroll the list or change the value based on the selection. To confirm some actions on the lists it must be pressed for 1 sec. the OK button. For **save the changes** the button Save must be kept pressed for 1 sec.

Main screens:

WRM60/90 M configuration

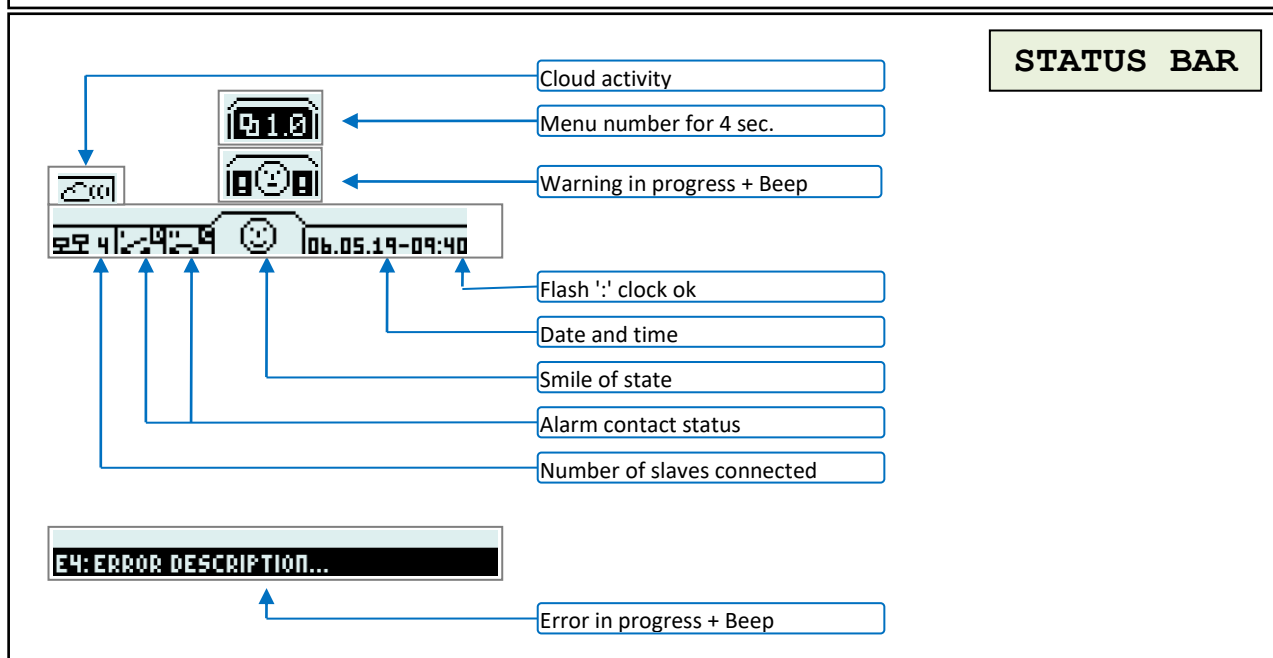
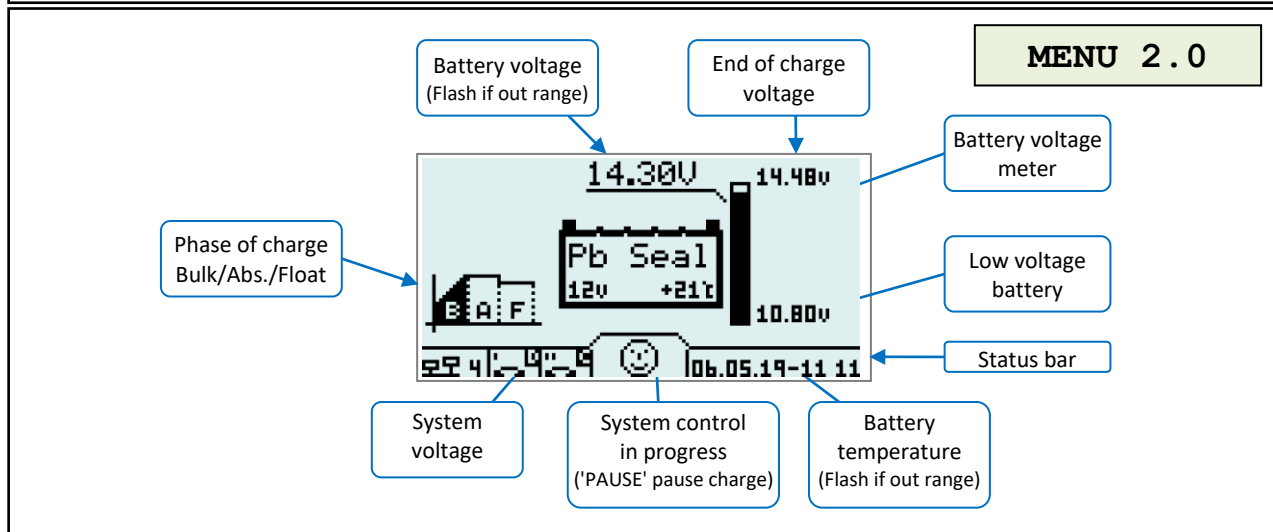
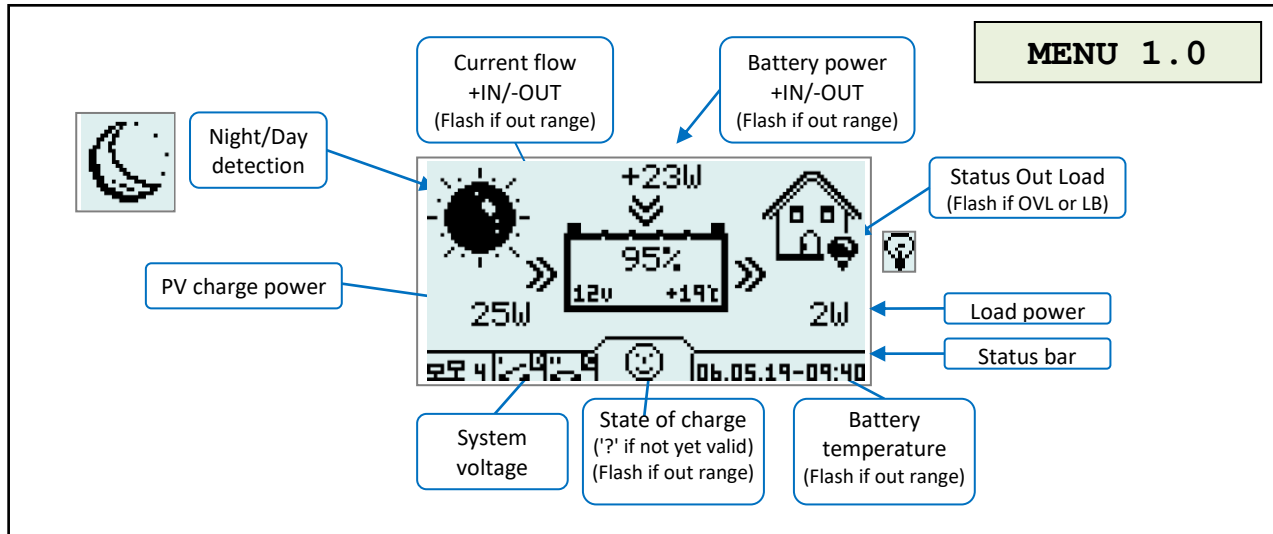

WRM60/90 M configuration

MENU 3.0

☀	V	A	W
☀	13.36	9.94	133
🔋	4.20	56	
🏠	5.74	77	
☐	3.0	VARIABLES	1.7%

Labels: Battery voltage (Flash if out range), PV charge current, PV charge power, Battery power IN/OUT (Flash if out range), Load power, Battery current IN/OUT (Flash if out range), Load current.

MENU 4.0

PV input n.1			
Ti+20t	V _{PV}	A _{PV}	W _{PV}
☀ A	27.12	2.83	77
☀ B	27.20	2.62	71
☐	4.0	PV STRINGS	227

Labels: internal temperature PV input hardware (Flash if over Temp.), PV input displayed, PV string voltage, PV string current, PV string power.

MENU 5.0

☀	kWh	Start
☀	000.000	06/05/19
🔋	000.000	06/05/19
🔋	000.000	
🏠	000.000	
☐	5.0	ENERGIES

Labels: PV production counter from Reset, Battery input counter from Reset, Battery output counter from Reset, Consumption counter from Reset³, Date of Reset WRM counters, Date of Reset WBM counters, n.Menu / Warning.

MENU 6.0

Info Warnings Error		
List of: All Events		
N.29-i	-Cod.259-	06/05/19-10:42.16
N.30-E	-Cod.541-	06/05/19-10:42.17
N.31-i	-Cod.403-	06/05/19-10:45.23
N.32-W	-Cod.152-	06/05/19-10:48.40
☐	6.0	LOG. EVENTS

Labels: Progressive number event (1..32), Oldest event occurring, Latest event occurring, Event list filter, Event type, Event code, Date and time event, n.Menu / Warning.

Setup Menu:

WRM60/90 M configuration

List displayed:	Value:	Settable value and descriptions:
MENU 7.0		
Settings:		
Batt.Type:	Pb Seal/	<p>WRM60/90 M-SB Master: Pb Flood 14.80@25°C / 29.60@25°C / 59.20@25°C : Setting to operate with Pb Flood type battery. Pb Seal/Gel 14.40@25°C/ 28.80@25°C / 57.60@25°C : Setting to operate with Pb Seal or Gel type battery. LiFePO4 <14.00..14.70V> <28.00..29.40V> <56.00..58.80V> fixed : Setting to operate with Lithium type battery with integrated BMS.</p> <p>WRM60/90 M-CB Master: LG Chem RESU %04.2fV fixed : Setting to operate with LG Chem RESU series battery PYLONTEC %04.2fV fixed : Setting to operate with PYLONTEC series battery (work in progress..)</p>
B.Capacity:	200Ah	<10..2000Ah> battery bank capacity, to compute SoC.
OFF disch.#1:	↓ 25%	<0%..ON disch> below this threshold, the ALARM output 1 is activated. Discharge OFF.
ON disch.#1:	↑ 40%	<OFF disch..100%> above this threshold, the ALARM output 1 is deactivated. Discharge ON.
OFF charge#2:	↑ 100%	<ON charge..100%> above this threshold, the ALARM output 2 is activated. Charge OFF.
ON charge#2:	↓ 90%	<0%..ON charge> below this threshold, the ALARM output 2 is deactivated. Charge ON.
Prog.Load:	OnSurplus	<p>24h/24h : LOAD output always active. <1..16h> : LOAD output active from sunset for the set hours. Only Night : LOAD output active only during the night. Only Day : LOAD output active only during the day. OnSurPlus : LOAD output active only during an energy surplus.</p>
LowB.Load:	11.12V	<10,8..12,56V> below this threshold, the LOAD output is activated.
<div style="border: 1px solid black; padding: 2px; display: flex; justify-content: space-between;"> 7.0 SYSTEM ⏪ </div>		

WRM60/90 M configuration

List displayed:	Value:	Settable value and descriptions:	MENU 7.1
Set Date Time:			
dd/mm/yy: 31/12/18		<1..31>/<1..12>/<00..99> days/months/years	
hh:mm:ss: 12:59.00		<0..23>:<0..59> hours:minutes.seconds	
TimeZone: UTC +1		<-12..+13> site timezone	
7.1 DATE / TIME			

List displayed:	Value:	Settable value and descriptions:	MENU 7.2
Info & Setting:			
sample Time: 10min		OFF : Data logger disabled (uSD CARD ejectable) <1..30min> logger sampling time.	
Info: -->		Logger information:	
NOT PRESENT		--> : select the type of information to show. If there is no card show "NOT PRESENT", and no information is available.	
Info: uSD CARD		uSD CARD : read the type of file system (NONE, FAT12/16/32) and calculates the free space on the card.	
File SYS: FAT32			
free space: 3772MB			
Info: Find WRD*.*		FIND WRD*.* : read and list the files one at a time by showing the name, size, and date of the last update. At the end shows "END LIST".	
WRDEVENT.LOG 27kB			
01/02/12 01:23:45			
WRDATA2.LOG 27kB			
01/02/12 01:23:45			
END LIST			
Info: SAMPLE EVENT		SAMPLE EVENT : show the remaining time for the next sampling	
00:30			
7.2 DATA LOGGER			

WRM60/90 M configuration

List displayed:	Value:	Settable value and descriptions:
MENU 7.3		
Item:	Value:	
CONNECTION	: OFF	← OFF; ON : Disable/Enable cloud connection to transfer data to the server.
Enable DHCP	: ON	← OFF; ON : Disable/Enable DHCP function.
1-IP Address	: 192	← <0..255> : set the device IP Address. <0..255> : " <0..255> : " <1..255> : " DHCP : set the Network Setup automatically (the other values will be ignored).
2-IP Address	: 168	
3-IP Address	: 100	
4-IP Address	: DHCP	
1-subNetMask	: 255	← <0..255> : set the subnet mask. <0..255> : " <0..255> : " <0..255> : "
2-subNetMask	: 255	
3-subNetMask	: 255	
4-subNetMask	: 000	
1-Gateway	: 255	← <0..255> : set the Gateway IP Address. <0..255> : " <0..255> : " <0..255> : "
2-Gateway	: 255	
3-Gateway	: 255	
4-Gateway	: 255	
1-prim.DNS	: 008	← <0..255> : set the primary DNS IP Address. <0..255> : " <0..255> : " <0..255> : "
2-prim.DNS	: 008	
3-prim.DNS	: 008	
4-prim.DNS	: 008	
1-secon.DNS	: 255	← <0..255> : set the secondary DNS IP Address. <0..255> : " <0..255> : " <0..255> : "
2-secon.DNS	: 255	
3-secon.DNS	: 255	
4-secon.DNS	: 255	
7.3 NETWORK		

WRM60/90 M configuration

List	Value:	Settable value and descriptions:	MENU 7.4
Network param. :			
status:	OFF-LINE	← OFF-LINE; ON-LINE : current status of cloud connection.	
IP :	192.168.100.067	← current device IP Address.	
sNM:	255.255.255.000	← current subnet mask.	
Gwy:	255.255.255.255	← current Gateway IP Address.	
DNS:	255.255.255.255	← current primary DNS IP Address.	
dns:	255.255.255.255	← current secondary DNS IP Address.	
MAC:	D880394F5632	← device MAC Address.	
KEY:	0123456789ABCDEF	← device KEY code.	
Device: rev.Fw:			
WRD	: 1.0	← firmware revision of the WRD device.	
WBM	: 1.0	← firmware revision of the WBM device.	
WRMxx	n.1: 1.0	← firmware revision of the WRMxx devices, from 1^ to 8^. (0.0 if device is not present)	
WRMxx	n.2: 1.0		
WRMxx	n.3: 0.0		
WRMxx	n.4: 0.0		
WRMxx	n.5: 0.0		
WRMxx	n.6: 0.0		
WRMxx	n.7: 0.0		
WRMxx	n.8: 0.0		
W-INVERTER	: 0.0	← firmware revision of the W-INVERTER device.	
7.4 SYSTEM INFO			

List displayed:	Value:	Settable value and descriptions:	MENU 7.5
Items :			
En. EvBeep:	ON	← OFF; ON : Disable/Enable sound alert.	
PAUSE Charge:	OFF	← OFF; ON : Pause the PV charge.	
Advanced Setup:	-->	← --> : Access to advanced setup menu 8.X.	
7.5 VARIOUS			

Configurazione WRM60/90 M

List displayed:	Value:	Settable value and descriptions:
MENU 8.0		
Device: Address:		
AutoConf: ---		RUN : starts the procedure to automatically identify the connected devices.
WBMonitor : 33		00; 33 : WBUS Address of the WBM device.
WRMxx n.1: 01		<0..32> : WBUS Address of the WRMxx devices, from 1^ to 8^. (00 if device is not present)
WRMxx n.2: 02		
WRMxx n.3: 00		
WRMxx n.4: 00		
WRMxx n.5: 00		
WRMxx n.6: 00		
WRMxx n.7: 00		
WRMxx n.8: 00		
W-INVERTER: 00		00; 34 : WBUS Address of the WI device.
8.0 WBUS CONFIG. ←		

WRM60/90 M configuration

List displayed:	Value:	Settable value and descriptions:
MENU 8.1		
WBM SETUP:		
Batt.Type: Pb Seal/		WRM60/90 M-SB Master: Pb Flood 14.80@25°C / 29.60@25°C / 59.20@25°C : Setting to operate with Pb Flood type battery. Pb Seal/Gel 14.40@25°C/ 28.80@25°C / 57.60@25°C : Setting to operate with Pb Seal or Gel type battery. LiFePO4 <14.00..14.70V> <28.00..29.40V> <56.00..58.80V> fixed : Setting to operate with Lithium type battery with BMS integrated.
B.Capacity: 200Ah		<10..2000Ah> battery bank capacity, to compute SoC.
OFF disch.#1: ↓ 25%		<0%..ON disch> below this threshold, the ALARM output 1 is activated. Discharge OFF.
ON disch.#1: ↑ 40%		<OFF disch..100%> above this threshold, the ALARM output 1 is deactivated. Discharge ON.
OFF charge#2: ↑ 100%		<ON charge..100%> above this threshold, the ALARM output 2 is activated. Charge OFF.
ON charge#2: ↓ 90%		<0%..ON charge> below this threshold, the ALARM output 2 is deactivated. Charge ON.
UPDATE FW: ---		RUN : *CAUTION* starts the procedure to update the firmware in the WBM device. The firmware update file must be present in the USD card.
<div style="border: 1px solid black; padding: 2px; display: flex; justify-content: space-between;"> 8.1 WBM ← </div>		

WRM60/90 M configuration

List displayed:	Value:	Settable value and descriptions:	MENU 8.2
WRM30 n.1 SETUP:		<1..8> select the WRM30 to edit.	
VEoCharge: 14.40V		Set the battery charge voltage: Pb Flood 14.80@25°C / 29.60@25°C / 59.20@25°C : Setting to operate with Pb Flood type battery. Pb Seal/Gel 14.40@25°C / 28.80@25°C / 57.60@25°C : Setting to operate with Pb Seal or Gel type battery. LiFePO4 <14.00..14.70V> <28.00..29.40V> <56.00..58.80V> fixed : Setting to operate with Lithium type battery with integrated BMS.	
VLowBatte: 12.56V		<12,00..12,56V> / <24,00..25,12V> / <48,00..50,24V> : below this threshold, the WRM30 goes into Low Battery status and deactivates the LOAD.	
VEndLBatt: auto		auto (VEoC-0,2/0,4/0,8V); <12,72..13,68V> / <25,44..27,36V> / <50,88..54,72V> : above this threshold, the WRM30 goes out Low Battery status and reactivates the LOAD.	
Prog.Load: 16hour		24h/24h : LOAD always active. <1..16h> : LOAD active from sunset for the set hours. Only Night : LOAD active only during the night. Only Day : LOAD active only during the day. OnSurPlus : LOAD active only during an energy surplus.	
VnightThd: 2.00V		2,00V; 3,28V; 4,56V; 5,84V : below this threshold, the WRM30 detect the sunset.	
MPPT algo: auto		auto; parall.; indep. : mode in which the MPPT algorithm considers the two channels.	
HrToFloat: 1hour		<1..8h> : time in Absorption phase before moving to Float phase.	
UPDATE FW: ---		RUN : *CAUTION* starts the procedure to update the firmware in the WBM device. The firmware update file must be present in the USD card.	
8.2 WRM30			

List displayed:	Value:	Settable value and descriptions:	MENU 8.3
WI SETUP:			
not present			
8.3 W-INVERTER			

WRM60/90 M configuration

List displayed:	Value:	Settable value and descriptions:	MENU 8.3
WRD SETUP:			
Oper.Mode: MONITOR		MONITOR; CONTROLLER : Operating Mode: Monitor/Controller	
Backlight: auto OFF		auto OFF; always ON : Backlight LCD: Auto power-OFF/ always ON	
RESET: RUN		RUN : Reset the WRD device.	
UPDATE FW: RUN		RUN : *CAUTION* starts the procedure to update the firmware in the WRD device. The firmware update file must be present in the USD card. To start the procedure press both ↑ and ↓ keys.	
Tech. Menu Psw: 00		<0..FF> password to access the Technical Menu. *CAUTION* Technical Menu is reserved for factory checks.	
8.3 WRD			

Electrical features

Parameter	Symb.	WRM60 M-SB Master	WRM60 M-CB Master	WRM60 S Slave	WRM90 M-SB Master	WRM90 M-CB Master	WRM90 S Slave	U.M.
Nominal battery voltage		12 / 24 / 48 autodetect						(V)
Battery voltage range (12/24/48V)	V _{bat}	10..16/ 20..32 / 40..64						(V)
Max charge current ¹	I _{ch}	60			90			(A)
Max charge power (12/24/48V)	P _{ch}	900 / 1800 / 3600			1350 / 2700 / 5400			(W)
Max open circuit voltage of PV string	V _{oc}	180						(V)
Max short circuit current of each PV string input	I _{sc_n}	26						(A)
Independent MPPT PV string input	PV _n	2			3			
Max power of each PV string input (12/24/48V)	P _{pv_n}	450 / 900 / 1800						(W)
Self consumption	P _q	1.0			1.2			(W)
Operating temperature	T _{amb}	-10..+40						(°C)
Max power dissipated (12/24/48V)	P _{loss}	80 / 112 / 132			120 / 168 / 198			(W)
Efficiency @ 60A (12/24/48V)	η	90 ÷ 92 / 93.5 ÷ 95.2 / 96.0 ÷ 97.2						(%)
Parallel slave operation		controlled via W-BUS						
Weight		6.275			8.75			(kg)
Dimension		370 x 386 x 113			545 x 386 x 113			(mm)
Degree of protection		IP20						
		WRM60/90 M-CB Master		WRM60/90 M-SB Master		WRM60/90 S Slave		
Smart Battery profiles		- LG Chem RESU 48V		-Generic profiles (Flood, Seal/Gel, Li)		sent from Master via W-BUS		
Working parameters		sent from BMS via CAN-BUS		sent from WBM via W-BUS				
Charge algorithm ²		multistage: Bulk / Absorption / Float						
Generic profiles				Pb-Flood	Pb-Seal-Gel	Lithium		
End of charge voltage @ 25°C (12V/24/48V)	V _{EoC_12} V _{EoC_24} V _{EoC_48}			14.8 29.6 59.2	14.4 28.8 57.6	14.0..14.7 28.0..29.4 56.0..58.8	parameters sent from Master via W-BUS	(V)
V _{EoC} temperature compensation ³ (12/24/48V)	V _{tadj}			-24 / -48 / -96				(mV/°C)
Float voltage (12/24/48V)	V _{fit}			V _{EoC} - (0.6 / -1.2 / -2.4)				(V)
Absorption time to float state	T _{abs}			4				(h)
Output LOAD topology ⁴		open drain						
Output LOAD voltage	V _{LOAD}	V _{batt}						(V)
Output LOAD current	I _{LOAD}	15						(A)
Output ALARM topology		Relay		Relay				
Output ALARM current	I _{ALA}	60Vdc 5A		60Vdc 0.1A				
Battery connection		M8 terminal						
Battery cable		pair of R/N 25mm ² 1.8m with ring terminal Ø8 (supplied)						
PV string input connection		2/3 pairs of M/F MC4 (connector supplied)						
Solar cable section for MC4 connectors		4/6mm ²						
Cable section for output LOAD connector		2.5mm ² connector supplied)						
Cable section for output ALARM connector		1.5mm ² (connector supplied)	0.5mm ² 1.8m (cable supplied)					
Internet cable connector		RJ45 (cable supplied)						
Control bus interface connector		RJ11 (cable supplied)						
Control bus interface topology		W-BUS						
Battery bus interface connector		RJ45 (cable supplied)		RJ11 (cable supplied)				
Battery bus interface topology		CAN		W-BUS				
External shunt device				WBM-Shunt (supplied)				
Battery connector on WBM-Shunt (negative)				hole Ø7 (18x20mm) (isolator + ring terminal supplied)				
Supply cable on WBM-Shunt				1mm ² 1.8m with ring terminal Ø8 (supplied)				
Electrical protection		Battery reverse polarity, temperature derating, overload.						

Tab.2 - Electrical features
¹The maximum charging current is limited to 30A for each PV input.

² With the Li program, the Float stage does not exist.

³ With the Li program, the V_{EoC} is not compensated in temperature.

⁴ Positive in common.

Charts

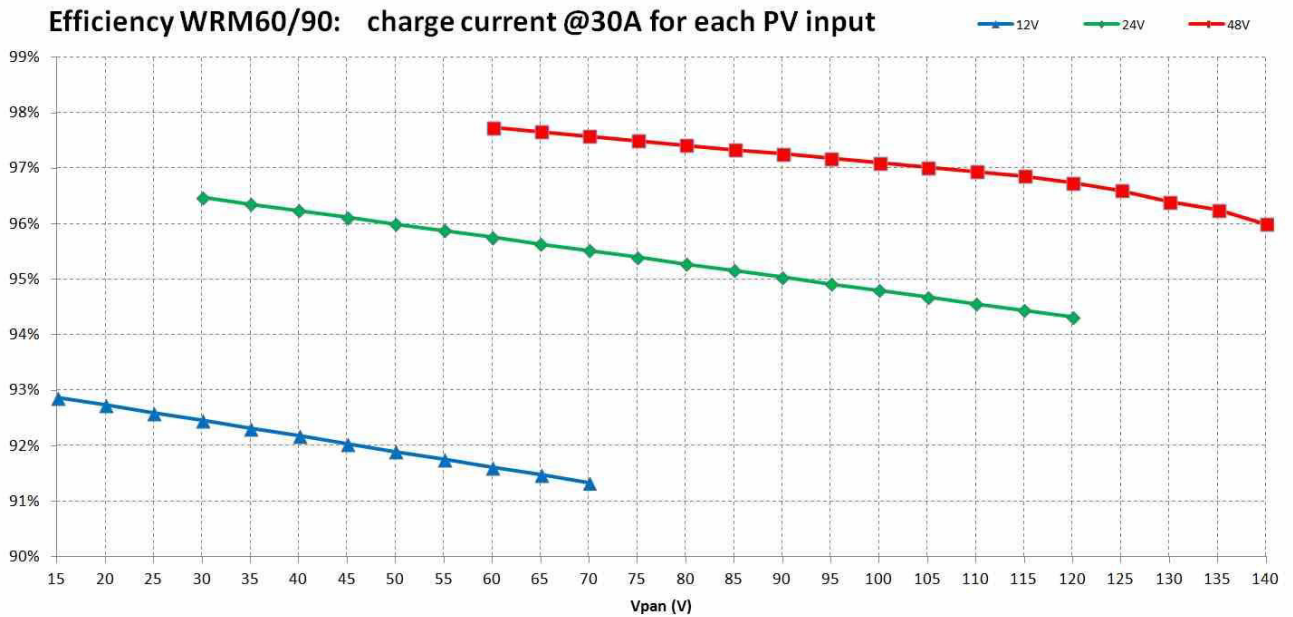

Pic.11 - Efficiency Chart

WRM60/90 DERATING CURVE



Pic.12 - Temperature Derating Chart

Dimensions

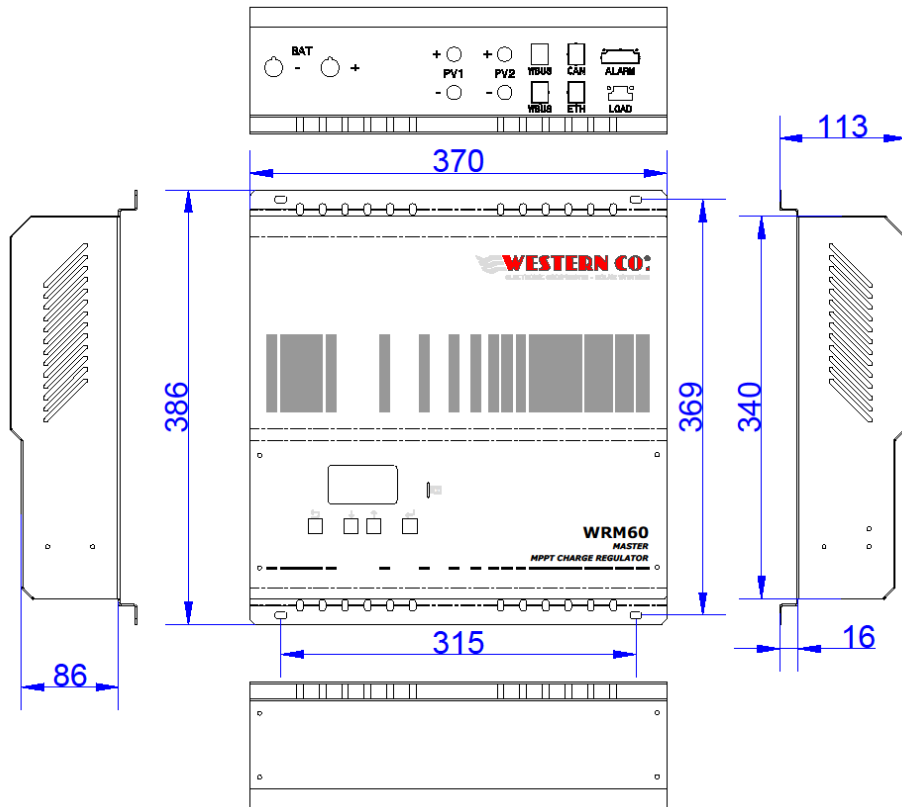

Pic.13 - WRM60 mechanical dimensions

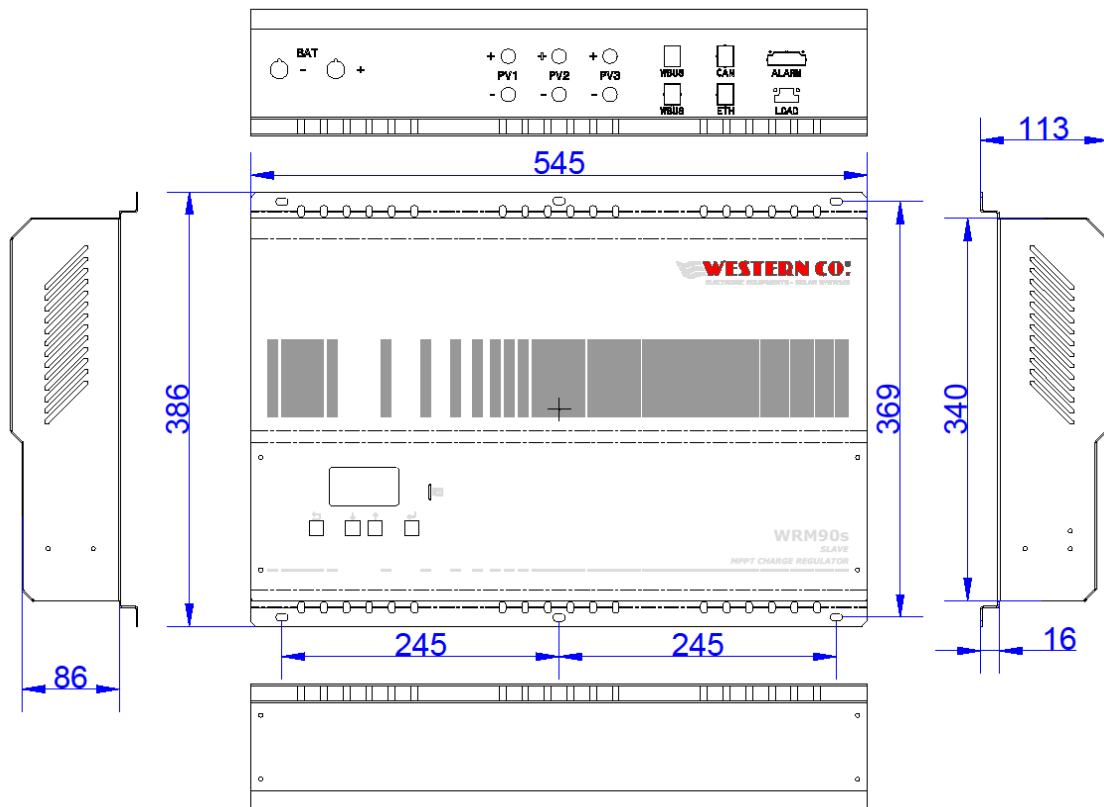

Pic.14 - WRM90 mechanical dimensions

Warranty

Western CO. Srl guarantees the good quality and good design of its own Products obliging itself, during the warranty period of 5 (five) years, to repair or replace at its sole discretion, for free, those defective parts owing to poor quality of material or defect in workmanship.

The defective product must be returned to Western Co. Srl or to the company delegated by Western Co to make product support, at customer's expenses, together with a copy of the invoice both for repairing and warranty replacement. The costs of re-installation of the equipment will be borne by the customer.

Western CO. Srl will bear the transport expenses of the repaired or replaced product.

All as indicated on the conditions of guarantees available on the page: <http://www.western.it/garanzia/>

The warranty does not cover Products that, according to our discretion, are defective due to natural wear, showing damages caused by incompetence or negligence of the customer, imperfect installation, by tampering or other interventions different by the instructions supplied by us.

The warranty is not valid also in case of damages coming from:

- transport and/or incorrect storage of the product.

force majeure or catastrophic events (frost to temperatures below -20° C, fire, flood, lightning, vandalism, and so on).

All of the above mentioned guarantees are the sole and exclusive agreement which supersedes any proposal or agreement, oral or written, and any other communication made between the manufacturer and the purchaser in respect of the above.

For any dispute the jurisdiction is Ascoli Piceno.

Waste disposal

Western CO. as manufacturer of the electrical device herein described and in accordance with DL 07/25/2005 n 151, informs the consumer that this product, once abandoned, must be delivered to an authorized collection centre or, in case of purchase of an equivalent equipment, it can be returned free of charge to the distributor of the new equipment.

The penalties will be applied by individual Municipalities.



Western CO. Srl
Via Pasubio, 1
63074 San Benedetto del Tronto (AP)
ph: (+39) 0735 751248 fax: (+39) 0735 751254
e-mail: info@western.it
web: www.western.it

Questo documento è di proprietà di WESTERN CO. Srl - Tutti i diritti sono riservati - La riproduzione e l'uso delle informazioni contenute nel presente documento sono vietati senza il consenso scritto di WESTERN CO. Srl.

This document is the property of WESTERN CO. Srl - All rights are reserved - Reproduction and use of information contained within this document is forbidden without the written consent of WESTERN CO. Srl.



WESTERN CO.
ELECTRONIC EQUIPMENTS - SOLAR SYSTEMS

Product Name
P/N XXXXXXX
S/N: XXXXXXXXX
Input: 12/24/48 VDC
CE



Scan the **QR CODE** placed on the side of the product or visit **www.western.it** to download the latest manual version.