

WESTERN CO
Via pasubio N°1
63074, San Benedetto del Tronto (AP) Italy
Tel. +39 0735 751248
info@western.it www.western.it

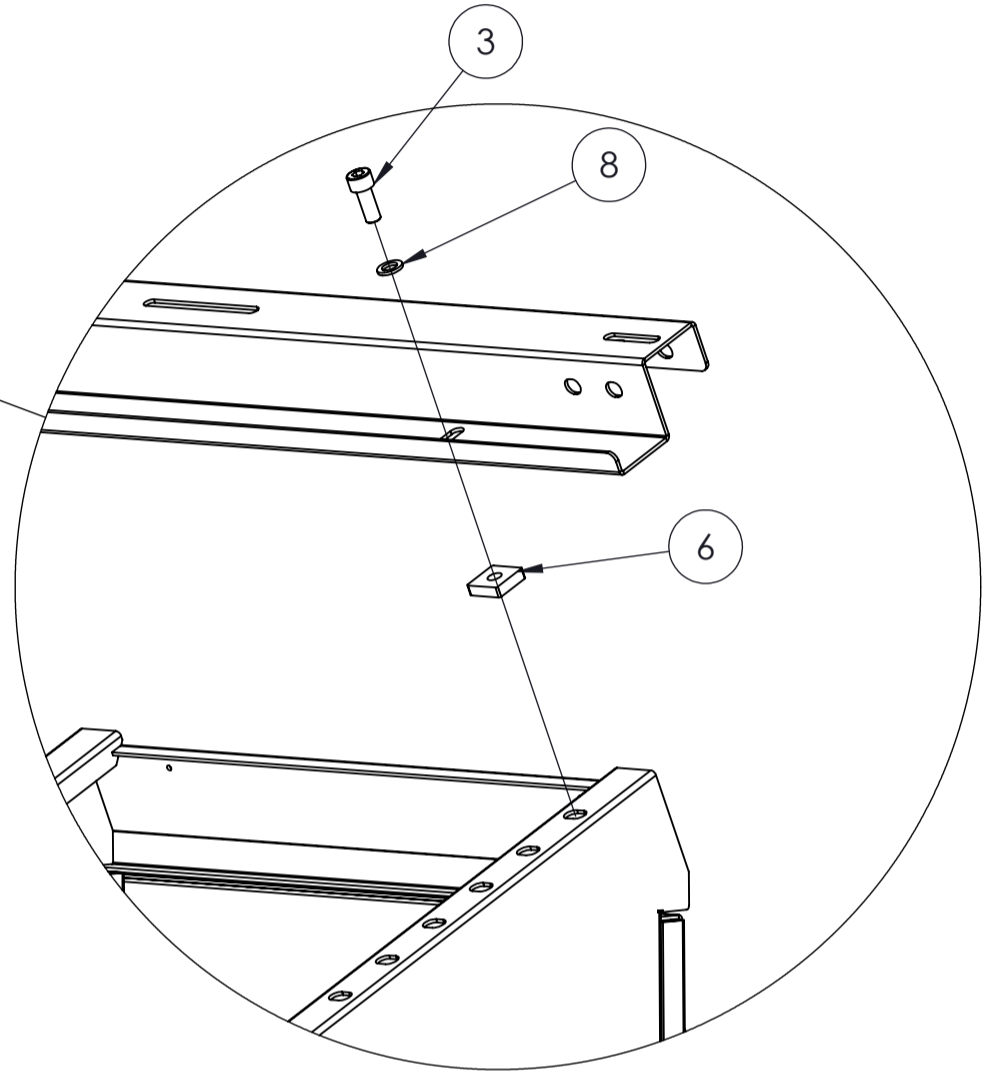

Per il montaggio del lampione fotovoltaico è obbligatorio l'uso della piattaforma aerea e dei dispositivi di protezione personali (guanti, calzature anti-infortunistiche e casco).
For the installation of the PV streetlamp is required to use the aerial work platform and personal protective equipment (i.e. gloves, anti-accident shoes and safety helmet)

STEP 1

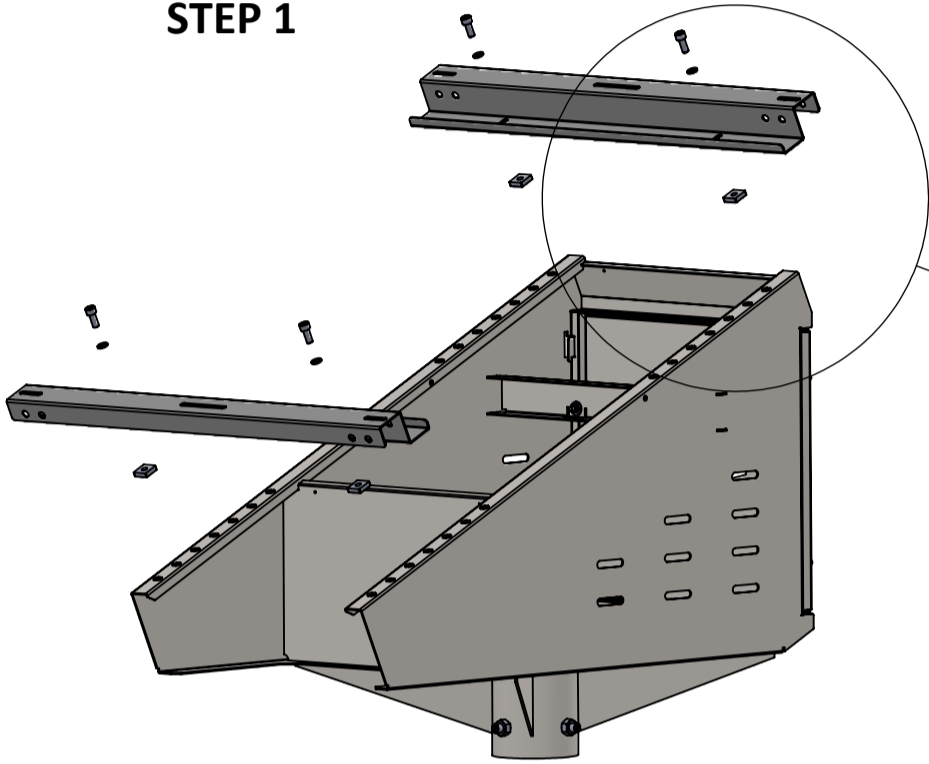

STEP 2

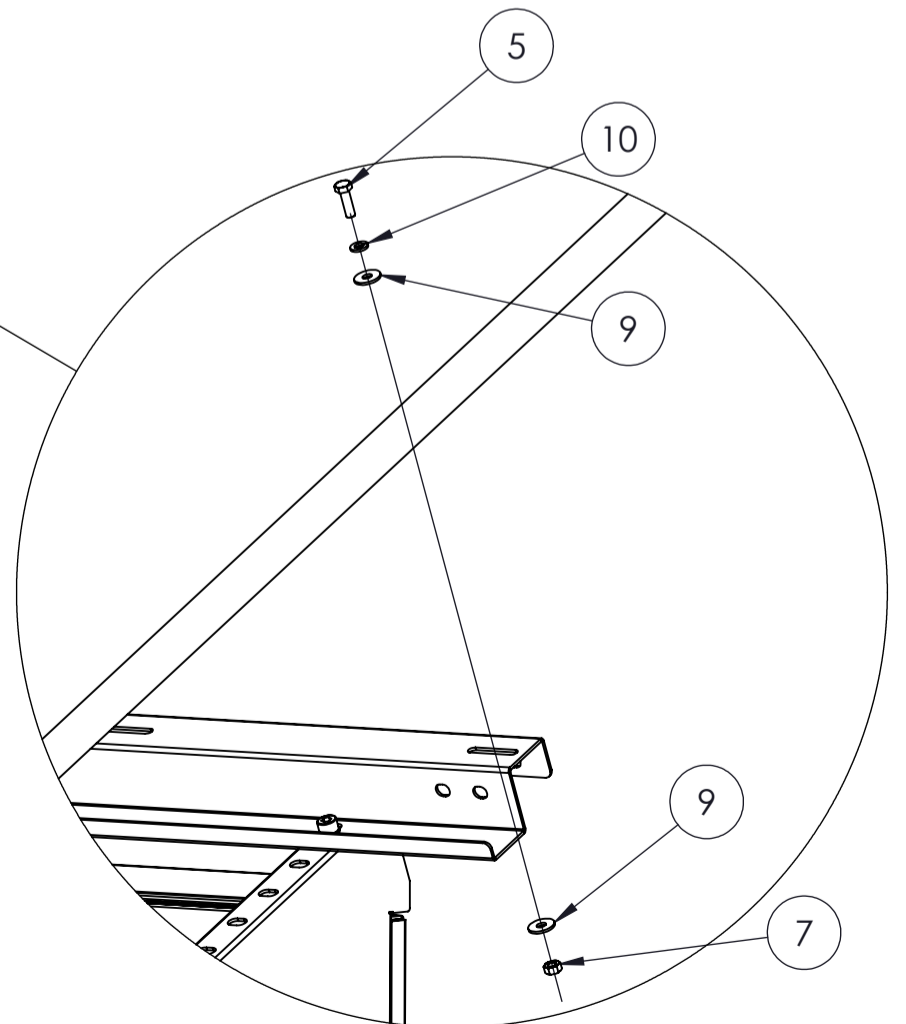
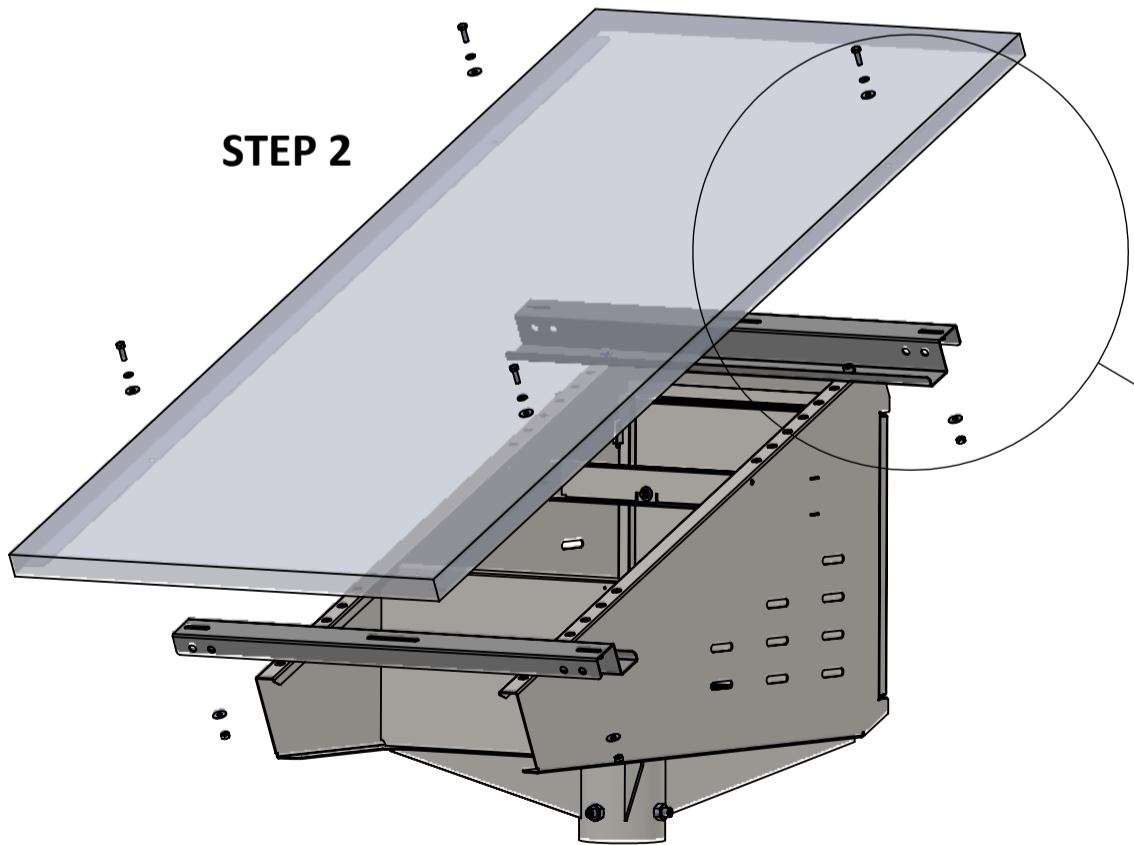

WESTERN CO
Via pasubio N°1
63074, San Benedetto del Tronto (AP) Italy
Tel. +39 0735 751248
info@western.it www.western.it

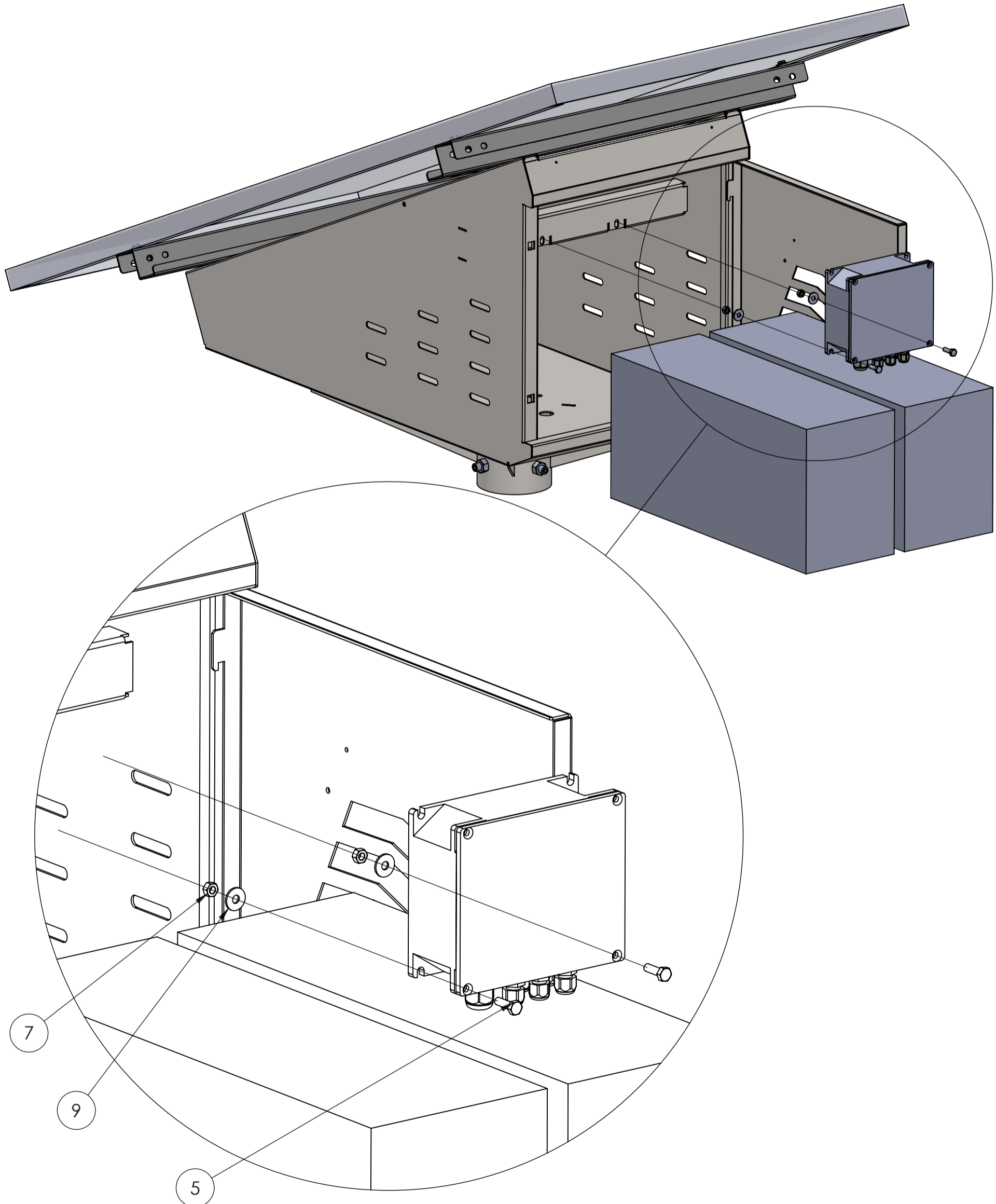

WESTERN CO
Via pasubio N°1
63074, San Benedetto del Tronto (AP) Italy
Tel. +39 0735 751248
info@western.it www.western.it



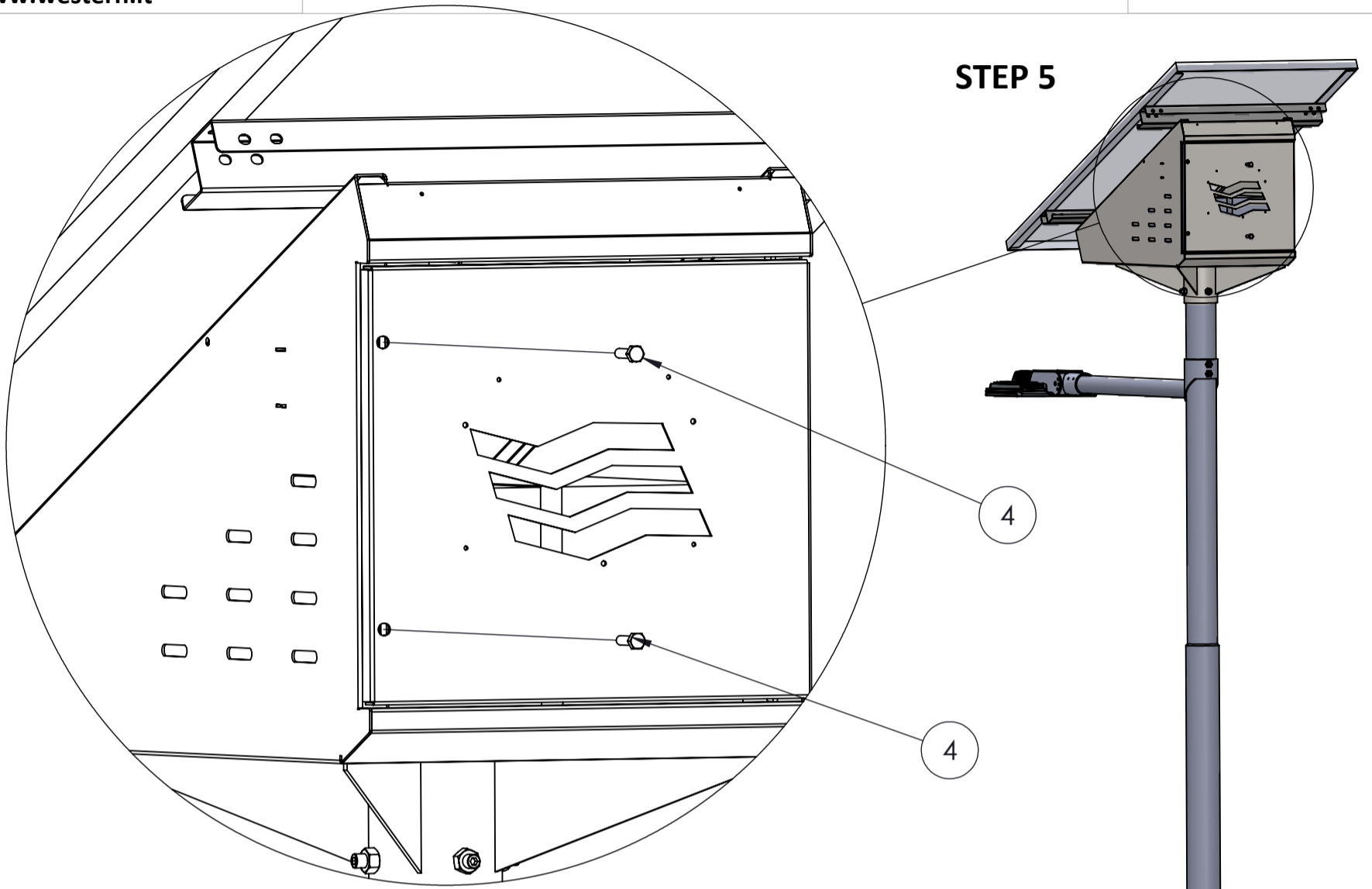



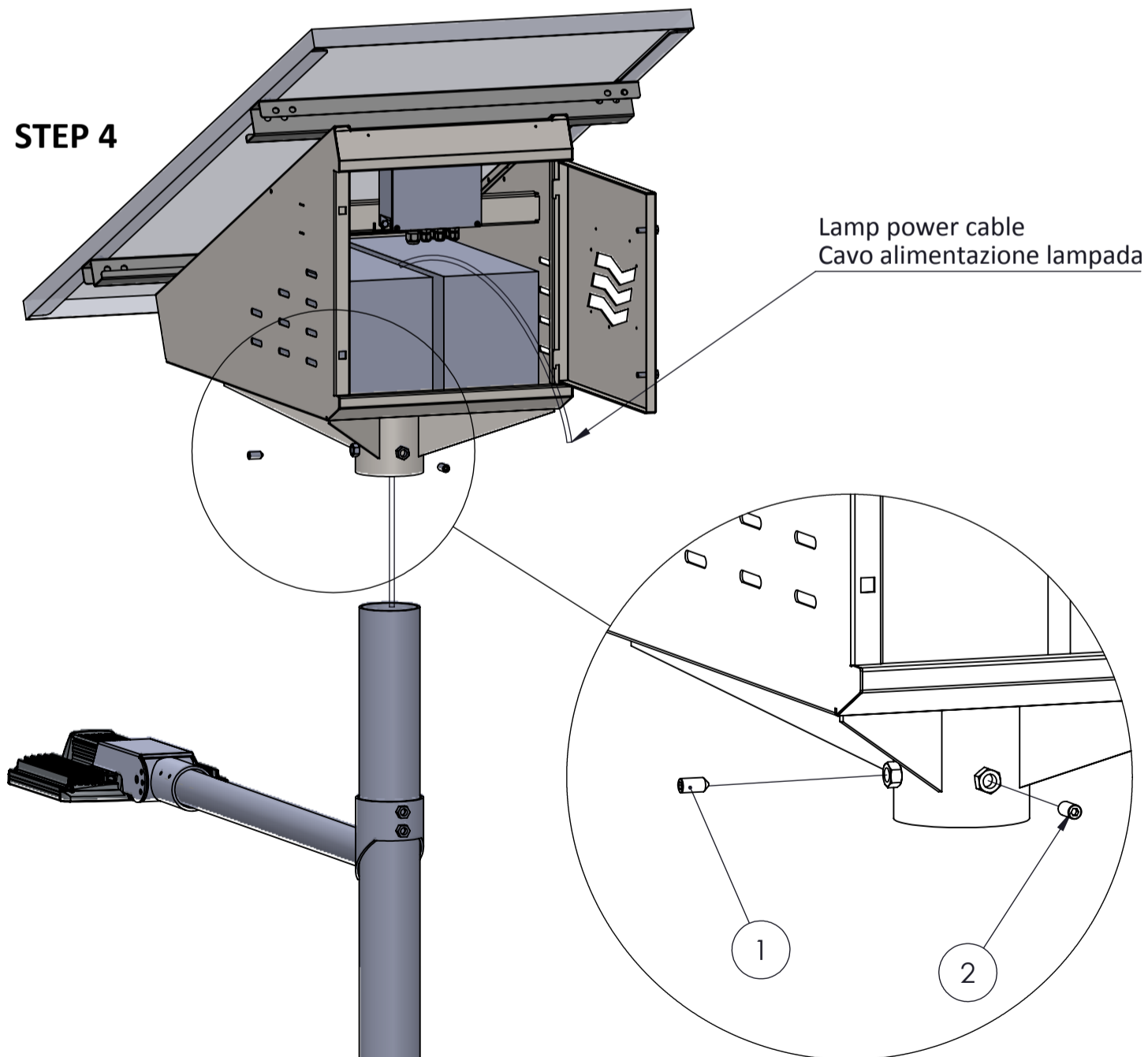

STEP 5



STEP 4

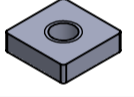

Lista bulloneria:
Fastners list:

Ref.			Q.ty
1		M12xL25	3
2		M12xL25	3
3		M8xL20	4
4		M8xL30	2
5		M6xL20	10
6		squared 22x22 M8	4
7		M6 D12	10
8		M8 D14	4
9		M6 D18	18
10		Grower M6	8

Piano di manutenzione del lampione fotovoltaico:

- 1) Sostituzione della lampada (ogni 1,5 anni per modelli con lampade SOX-E, ogni 15 anni per modelli con lampada led)
- 2) Sostituzione delle batterie (ogni 4 anni per batterie VRLA, ogni 10 anni per batterie LiFePO4)
- 3) Ogni 2 anni si deve eseguire un controllo a vista del palo e delle saldature sulla struttura testapalo. Nel caso si riscontrano zone ossidate è necessario intervenire localmente con della vernice zincante.

Photovoltaic streetlight maintenance plan:

- 1) Lamp replacement (every 1.5 year for SOX-E lamp, every 15 year for led lamp)
- 2) Battery replacement (every 4 year for VRLA battery, every 10 year for LiFePO4 battery)
- 3) Every 2 years you must perform a visual check of the pole and welds in the battery box. If you are having oxidized zones is necessary to act locally with zinc paint.