

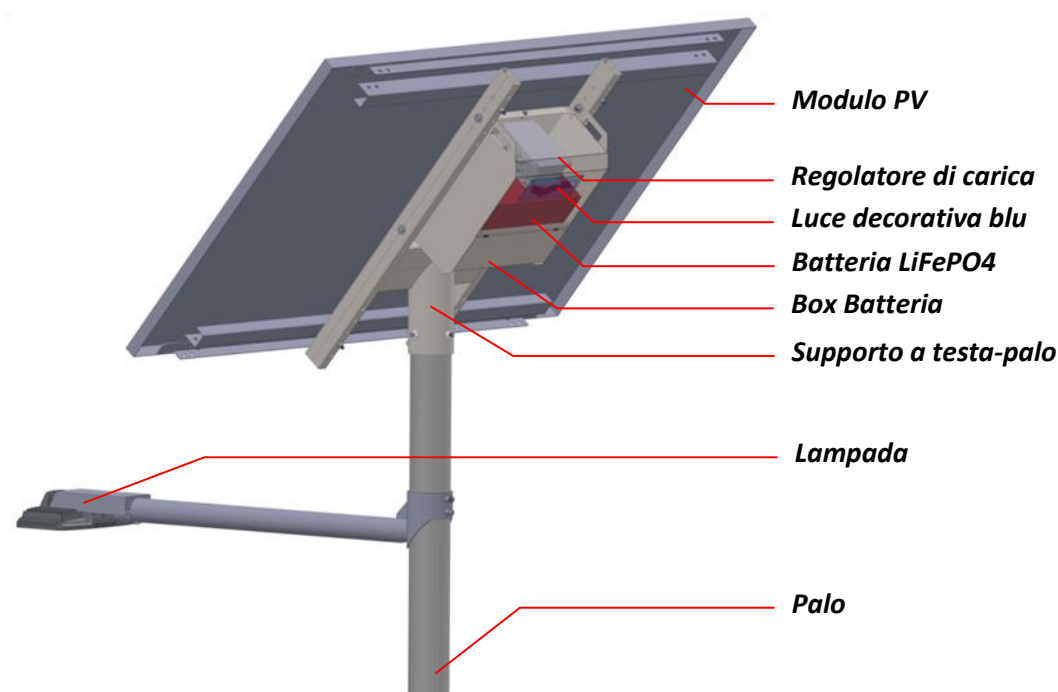

**Descrizione:** SSL-Li è la nuova serie di lampioni fotovoltaici Western CO con batteria a Litio (LiFePO4), presentano un nuovo design compatto, migliori prestazioni in termini di durata della batteria, maggiore efficienza e una maggiore garanzia di accensione lampada anche nei periodi di cattivo tempo e scarsa insolazione. Il lampione è composto dal modulo fotovoltaico, dalla batteria a tecnologia Litio (LiFePO4), dal regolatore di carica, dalla lampada a led alta efficienza con ottica asimmetrica ottimizzata per illuminazione di strade o parcheggi e dalla struttura meccanica in acciaio zincato a caldo per il montaggio del modulo e della batteria in testa al palo. Western CO fornisce a richiesta anche il palo lunghezza 7.0 metri fuori terra.

Il regolatore di carica del lampione SSL-Li implementa una connessione bluetooth; attraverso una applicazione Android installabile su un qualsiasi smartphone dotato di porta bluetooth è possibile controllare lo stato di funzionamento del lampione, modificare le impostazioni di accensione della lampada e monitorare lo stato di salute della batteria.



Regolatore di carica  
**SPB-L/BT**



- Circuito di carica della batteria ad alta efficienza con ricerca del punto di massima potenza del modulo fotovoltaico (**MPPT**). Range tensione modulo PV da 20V a 100V.
- Accensione automatica notturna su uscita lampada con timer a numero di ore limitato (12 ore) e programmabile (la lampada si accende automaticamente la notte per un numero limitato di ore per notte).
- Gestione automatica della riduzione di flusso programmabile al **70%** o al **50%**.
- Ricarica ottimizzata per batterie al litio (LiFePo4 con tensione 14.4V), protezione della carica in caso di temperatura < 0°C e > 45°C.
- Protezione inversione polarità su ingresso batteria e ingresso modulo PV.
- Protezione batteria da scarica profonde.
- Protezione alla penetrazione di liquido e solidi IP66 (EN 60529).
- Garanzia del produttore **5 anni**.
- Conforme a:
  - Direttiva 2004/108/CE – EMC (**EN 61000-6-1** e **EN 61000-6-3**)
  - Direttiva 2006/95/CE – Bassa Tensione (**EN 62109-1**)
- Controllo remoto Bluetooth; permette settaggio parametri accensione lampada e accesso a logger dati da remoto attraverso applicazione Android o software PC.

Lampada







- Corpo in alluminio estruso e anodizzato, grado protezione alla penetrazione di solidi e liquidi IP65(EN 60529).
- Temperatura di colore 4000K, CRI minimo 70.
- Ottica stradale ad alta efficienza. Rilievi fotometrici dell'apparecchio formato elettronico LDT.
- Conforme a DECRETO 27 settembre 2017 (Ministero dell'Ambiente e della tutela del Territorio e del mare) decreto **CAM, Criteri Ambientali Minimi** per l'acquisizione di sorgenti luminose per illuminazione pubblica ...
- Garanzia produttore **5 anni**.
- Disponibili le seguenti potenze:

CODICE	NUMERO LED	POTENZA @ Tq=25°C [W]	CORRENTE LED [mA]	FLUSSO NOMINALE LED @ Tj=85°C [lm]	FLUSSO APPARECCHIO @ Tq=25°C [lm]	EFFICIENZA APPARECCHIO @ Tq=25°C [lm/W]
WL24N	12	24,7	650	3360	2955	120
WL30N	12	31,3	820	3912	3403	109
WL36N	12	37,4	960	4270	3716	101
WL42N	12	43,1	1150	4944	4302	100
WL60N	24	62,8	820	7824	6807	108
WL72N	24	74,8	960	8544	7433	101
WL84N	24	86,2	1150	9888	8602	100

Batteria

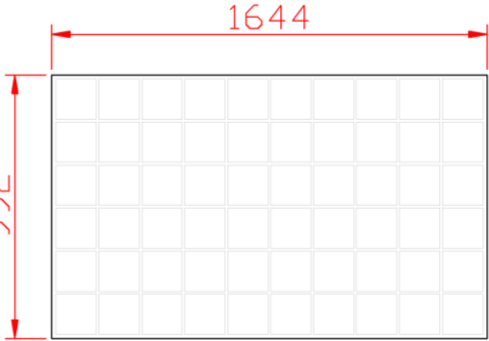

- Batteria a litio
- Tipologia LiFePO4 ad elevata sicurezza.
- Disponibili con capacità **60Ah e 100Ah** a 12.8V nominali.
- Bilanciamento interno delle celle e protezione interna da sovraccarica in tensione, sovraccarico in corrente sia in carica che in scarica, sovra-temperatura.
- Intervallo di temperatura operativo da -10°C a 55°C; intervallo temperatura in carica da +0°C a 45°C e intervallo operativo di scarica da -10°C a 55°C.
- Vita ciclica **>2500 cicli a 80% DOD** (Deep Of Discharge).-
- Conforme a **UN 38.3** Lithium ion battery safety testing.

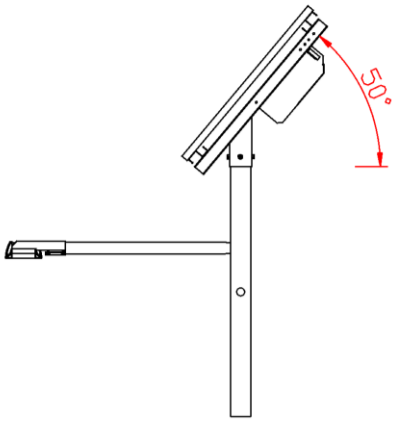
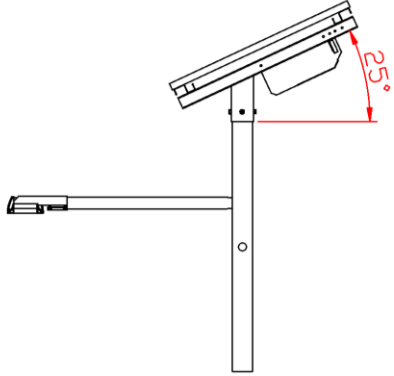
<p>Modulo fotovoltaico</p> 	<ul style="list-style-type: none"> <li>-Celle <b>monocristalline/policristalline</b> ad alta efficienza, certificato secondo le normative <b>IEC 61215</b> e <b>IEC 61730</b>.</li> <li>-Garanzia sulla potenza resa &gt; 90% entro 12 anni e maggiore dell'80% entro 25 anni.</li> <li>-Carico meccanico fino a 5400Pa (N/m<sup>2</sup>).</li> <li>-Scatola di giunzione protetta alla penetrazione liquidi o solidi IP67 (EN 60529).</li> <li>-Garanzia produttore <b>5 anni</b>.</li> <li>-Possibilità di montare due taglie di moduli con potenza <b>160W</b> e <b>300W</b></li> </ul> <div style="display: flex; justify-content: space-around; align-items: center;"> <div style="text-align: center;">  <p><i>dimensioni modulo pv 160W</i></p> </div> <div style="text-align: center;">  <p><i>dimensioni modulo pv 300W</i></p> </div> </div>
<p>Accessori meccanici per montaggio modulo PV e batteria in testa al palo</p> 	<ul style="list-style-type: none"> <li>-Struttura meccanica e accessori in acciaio zincato a caldo secondo <b>EN ISO 1461</b>.</li> <li>-Costruito secondo <b>EN 1090</b> (Esecuzione di strutture in acciaio ed alluminio) e corredato della relativa DoP (Dichiarazione di Prestazione).</li> <li>-Calcolo strutturale secondo <b>Eurcodice 0, 1, 3</b> e <b>DM 17/01/2018</b> Ministero delle Infrastrutture e dei Trasporti (<b>Norme Tecniche delle Costruzioni</b>).</li> </ul> <div style="display: flex; justify-content: space-around; align-items: center;"> <div style="text-align: center;">  <p><i>SSL-Li 50 tilt modulo 50°</i></p> </div> <div style="text-align: center;">  <p><i>SSL-Li 25 Tilt modulo 25°</i></p> </div> </div>

### Dimensioni

SSL-Li 50 con modulo PV 160W

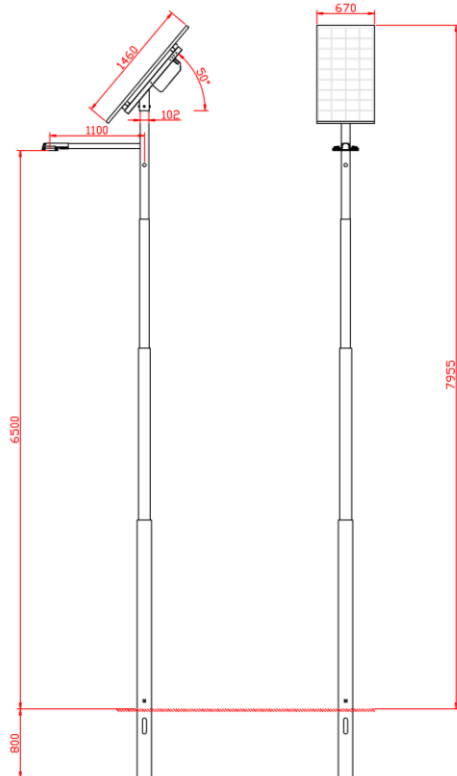

SSL-Li 50 con modulo PV 300W

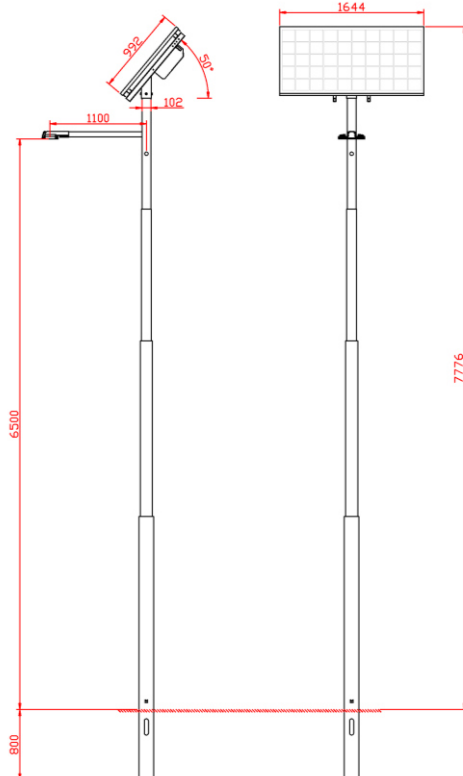

SSL-Li 25 con modulo PV 160W

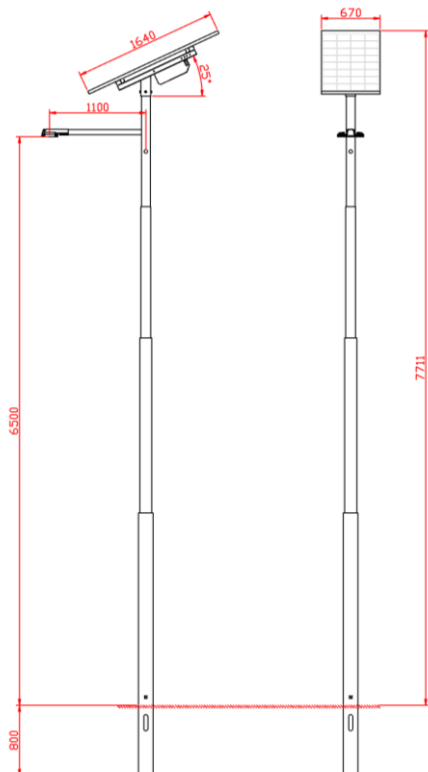

SSL-Li 25 con modulo PV 300W

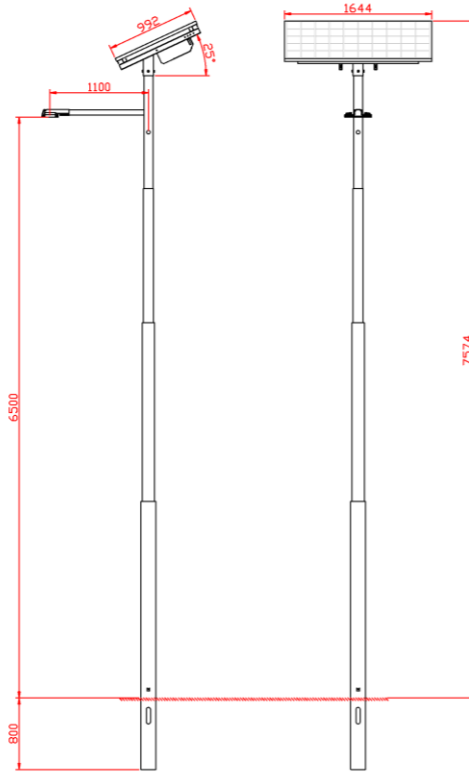

**WESTERN CO. Srl**

Via Pasubio, 1

63074 San Benedetto del Tronto (AP)

tel: (+39) 0735 751248 fax: (+39) 0735 751254

e-mail: [info@western.it](mailto:info@western.it) web: [www.western.it](http://www.western.it)



**Description:** SSL-Li is the new series of Western CO photovoltaic street lamps with Lithium battery (LiFePO4), they feature a new compact design, better performance in terms of battery life, greater efficiency and greater guarantee of lamp lighting even during periods of bad weather and poor sunshine. The Street lamp is made up of photovoltaic module, lithium technology battery (LiFePO4), charge controller, high efficiency LED lamp with asymmetric optics optimized for lighting streets or parking lots and mechanical structure in hot-galvanized steel for PV Module mounting and battery at the top of the pole. Western CO also supplies 7.0 meter long pole above ground on request. The SSL-Li street lamp charge controller implements a bluetooth connection; through an Android application that can be installed on any smartphone equipped with a Bluetooth port, it is possible to check the functioning status of the lamp, change the settings for switching on the lamp and monitor the health of the battery.

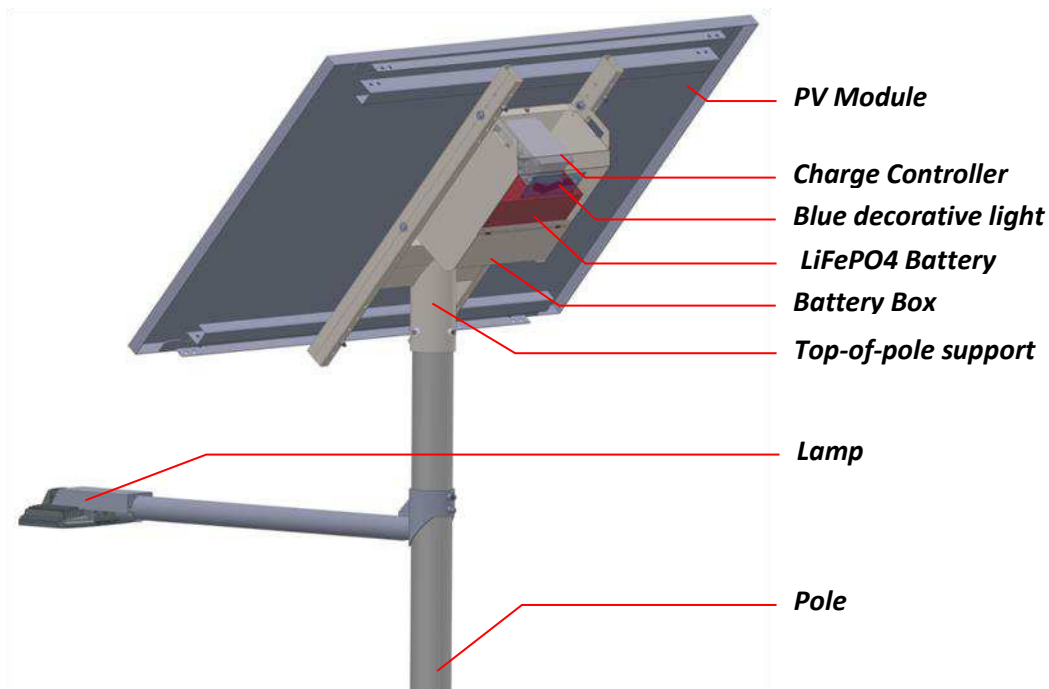

**Charge Controller**  
**SPB-L/BT**



- High efficiency battery charging circuit with search of the maximum power point of the photovoltaic module (MPPT). PV module voltage range from 20V to 100V.
- Automatic night switch on lamp output with timer at limited number of hours (12 hours) and programmable (the lamp turns on automatically at night for a limited number of hours per night).
- Automatic management of flow reduction programmable at **70%** or **50%**.
- Optimized charging for lithium batteries (LiFePO4 with 14.4V voltage), charge protection in case of temperature <0 ° C and > 45 ° C.
- Reverse polarity protection on battery input and PV module input.
- Deep discharge battery protection.
- Protection against penetration of liquid and solids IP66 (EN 60529).
- Manufacturer warranty **5 years**.
- Compliant with :
  - Directive 2004/108/CE – EMC (**EN 61000-6-1** e **EN 61000-6-3**)
  - Directive 2006/95/CE – Low Voltage (**EN 62109-1**)
- Bluetooth remote control; allows setting parameters for lamp lighting and access to data logger remotely through Android application or PC software.

**Lamp**





- Extruded and anodized aluminum body, able to protect solid and liquid penetration IP65 (EN 60529).
- Color temperature 4000K, minimum CRI 70.
- Photometric measurements of the electronic format device LDT
- Compliant with DECREE 27 September 2017 (Ministry of the Environment and the Protection of the Territory and the Sea) **CAM** decree, **Minimum Environmental Criteria** for the acquisition of light sources for public lighting ...
- Manufacturer warranty **5 years**
- The following powers are available:

CODE	NO.Of LEDs	POWER @ Tq=25°C [W]	LED CURRENT [mA]	NOMINAL LED FLUX @ Tj=85°C [lm]	LUMINAIRE FLUX@ Tq=25°C [lm]	LUMINAIRE EFFICIENCY @ Tq=25°C [lm/W]
WL24N	12	24,7	650	3360	2955	120
WL30N	12	31,3	820	3912	3403	109
WL36N	12	37,4	960	4270	3716	101
WL42N	12	43,1	1150	4944	4302	100
WL60N	24	62,8	820	7824	6807	108
WL72N	24	74,8	960	8544	7433	101
WL84N	24	86,2	1150	9888	8602	100

**Battery**

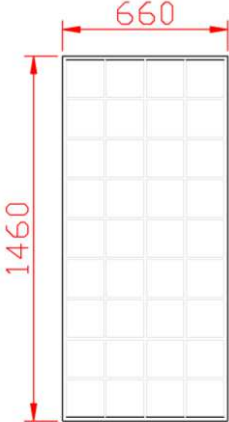
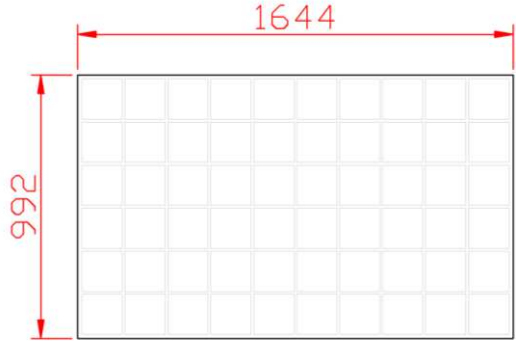

- Lithium Battery
- High security LiFePO4 type.
  - Available with 60Ah and 100Ah capacity at 12.8V nominal.
  - Internal balancing of the cells and internal protection against voltage overload, current overload in both charging and discharging, over-temperature.
  - Operating temperature range from -10 ° C to 55 ° C; temperature range in charge from + 0 ° C to 45 ° C and operational discharge range from -10 ° C to 55 ° C.
  - Cyclical life> **2500 cycles at 80% DOD** (Deep Of Discharge)
  - Compliant with **UN 38.3** Lithium ion battery safety testing

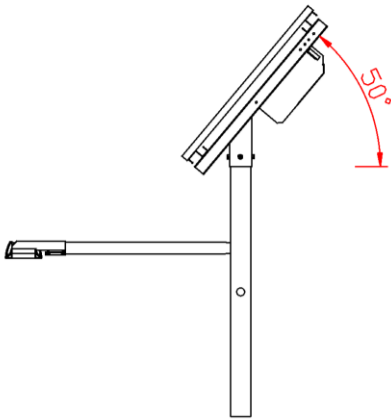
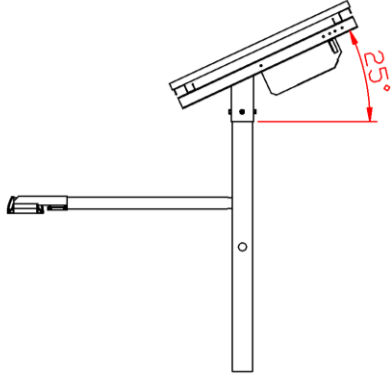
<p>PV Module</p> 	<ul style="list-style-type: none"> <li>- High efficiency <b>monocrystalline / polycrystalline</b> cells, certified according to <b>IEC 61215</b> and <b>IEC 61730</b></li> <li>-Performance guarantee &gt; 90% within 12 years and greater than 80% within 25 years.</li> <li>-Mechanical load up to 5400Pa (N / m<sup>2</sup>).</li> <li>- Junction box protected against penetration of liquids or solids IP67 (<b>EN 60529</b>).</li> <li>- Manufacturer warranty <b>5 years</b></li> <li>- Possibility to mount two sizes of modules with <b>160W</b> and <b>300W power</b></li> </ul> <div style="display: flex; justify-content: space-around; align-items: center;"> <div style="text-align: center;">  <p><i>Dimensions of pv 160W module</i></p> </div> <div style="text-align: center;">  <p><i>Dimension of pv 300W module</i></p> </div> </div>
<p>Mechanical accessories for mounting PV module and battery at top of the pole</p> 	<ul style="list-style-type: none"> <li>- Mechanical structure and accessories in hot galvanized steel according to <b>EN ISO 1461</b>.</li> <li>-Constructed according to <b>EN 1090</b> (Execution of steel and aluminum structures) and accompanied by the related DoP (Declaration of Performance).</li> <li>-Structural calculation according to <b>Eurcodice 0, 1, 3</b> and <b>DM 17/01/2018</b> Ministry of Infrastructures and Transports (Construction Technical Standards).</li> </ul> <div style="display: flex; justify-content: space-around; align-items: center;"> <div style="text-align: center;">  <p><i>SSL-Li 50 tilt module 50°</i></p> </div> <div style="text-align: center;">  <p><i>SSL-Li 25 tilt module 25°</i></p> </div> </div>



**Dimensions**

*SSL-Li 50 with PV 160W Module*

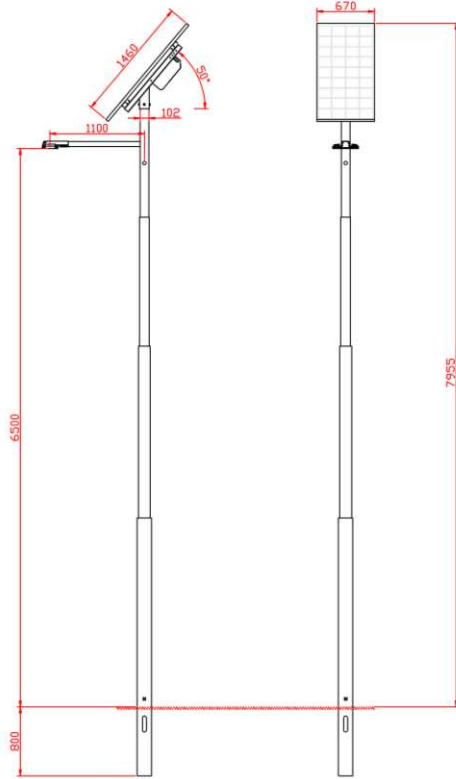

*SSL-Li 50 with PV 300W Module*

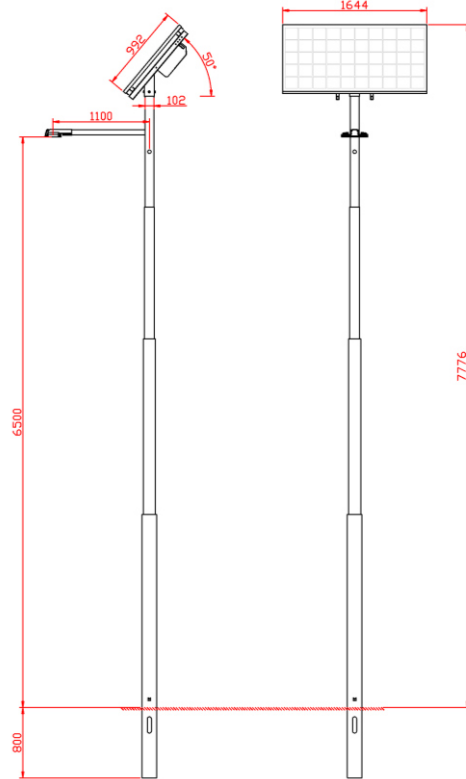

*SSL-Li 25 with PV 160W Module*

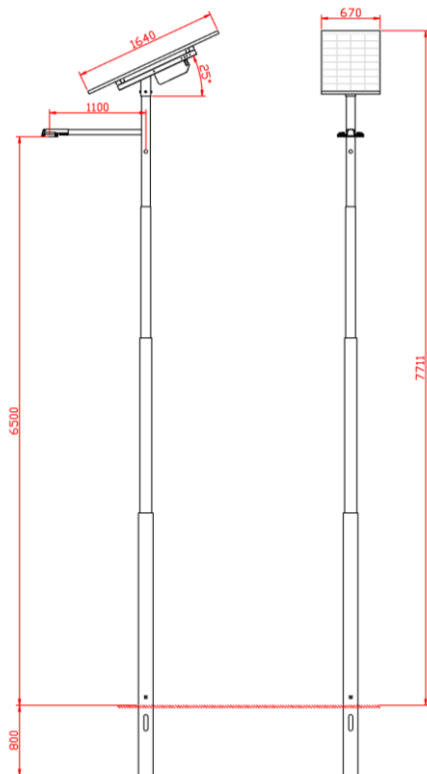

*SSL-Li 25 with PV 300W Module*

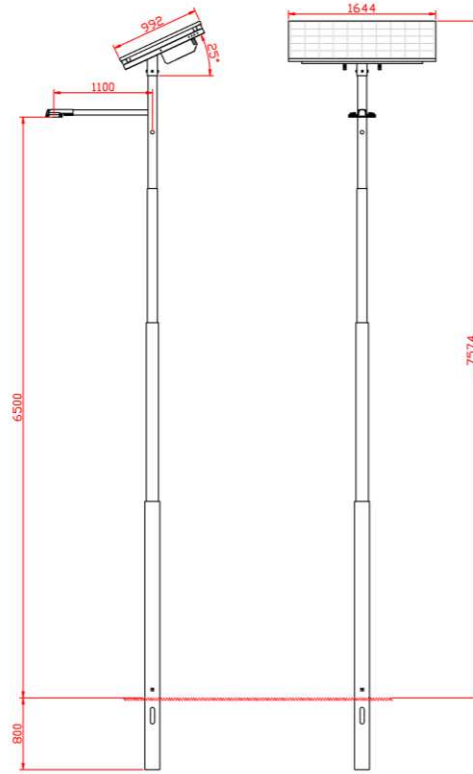

**WESTERN CO. Srl**

Via Pasubio, 1

63074 San Benedetto del Tronto (AP)

tel: (+39) 0735 751248 fax: (+39) 0735 751254

e-mail: [info@western.it](mailto:info@western.it) web: [www.western.it](http://www.western.it)